



Cat. No. 01033136

Rev. D 05/19/21
DCO # 210095

ClearLink Wireless Filtration Control

Models from 2021



Installation,
Operation, and
Service Instructions
with Parts Lists

Attention Culligan Customer:

Your local independently operated Culligan dealer employs trained service and maintenance personnel who are experienced in the installation, function and repair of Culligan equipment. This publication is written specifically for these individuals and is intended for their use.

We encourage Culligan users to learn about Culligan products, but we believe that product knowledge is best obtained by consulting with your Culligan dealer. Untrained individuals who use this manual assume the risk of any resulting property damage or personal injury.

NOTICE Please send any suggestions for improving this manual to productmanuals@culligan.com



WARNING! Electrical shock hazard! Prior to servicing equipment, disconnect power supply to prevent electrical shock.



WARNING! If incorrectly installed, operated, or maintained, this product can cause severe injury. Those who install, operate, or maintain this product should be trained in its proper use, warned of its dangers, and should read the entire manual before attempting to install, operate, or maintain this product. Failure to comply with any warning or caution that results in any damage will void the warranty.



CAUTION! This product is not to be used by children or persons with reduced physical, sensory or mental capabilities, or lack of experience or knowledge, unless they have been given supervision or instruction.



CAUTION! Children should be instructed not to play with this appliance.



CAUTION! If the power cord from the power supply to the unit looks or becomes damaged, the cord and power supply should be replaced by a Culligan Service Agent or similarly qualified person in order to avoid a hazard.

NOTE This system is not intended for use with water that is microbiologically unsafe or of unknown quality without adequate disinfection either before or after the system.

NOTE Check with your public works department for applicable local plumbing and sanitation codes. Follow local codes if they differ from the standards used in this manual. To ensure proper and efficient operation of the Culligan ClearLink to your full satisfaction, carefully follow the instructions in this manual.

Products manufactured and marketed by Culligan International Company (Culligan) and its affiliates are protected by patents issued or pending in the United States and other countries. Culligan reserves the right to change the specifications referred to in this literature at any time without prior notice. Culligan, Aqua-Sensor, Tripl-Hull, and SoftMinder are trademarks of Culligan International Company or its affiliates.

Culligan International Company
9399 West Higgins Road, Suite 1100
Rosemont, Illinois 60018
1-847-430-2800
www.culligan.com

Installation, Operation, and Service Instructions with Parts Lists



Culligan® ClearLink™ Wireless Filtration Control

Models from 2021

Contents

Read this Manual First.....	5	Leak Sensor Installation	18
Introduction.....	5	Button Display Guide	22
About this Manual	6	Culligan Connect App Installation for Aquasential® ClearLink™ PRO	24
Safe Practices.....	6	Culligan Connect App Installation for all other ClearLink™ products	24
Serial Numbers	6	Pairing to Smart Device	24
ClearLink™ PRO.....	7	Pair to iPhone or iPad.....	26
ClearLink™ Connect.....	7	Viewing Device On C-Port	27
About Models.....	7	Best Practices for Installations.....	28
Drinking Water Connect.....	8	Troubleshooting	28
Aquasential® ClearLink™ PRO	9	Troubleshooting Guide	29
Parts Included:.....	10	Control Box Lights	29
Tools and Materials Required	10	Service.....	30
Specifications.....	10	Flow Path Diagrams	31
Precautions.....	10	Routing Guides	33
Installation	10	Installation Fittings and Replacement Parts List.....	37
Setting Capacity and TDS Function (All Models).....	11	Two-Year Limited Warranty	39
Installation (All Models).....	12	Index.....	40
External Flow Switch for a Secondary Outlet	16		
Flow Switch 40' Wire Extension Kit (if applicable).....	18		

This page intentionally left blank.

Read this Manual First

Before you operate the Culligan® ClearLink™ systems, read this manual to become familiar with the device and its capabilities.

The Aquasential® ClearLink™ PRO, ClearLink™ PRO, ClearLink™ Connect, and Drinking Water Connect manifolds are certified by WQA against CSA B483.1, NSF/ANSI 372 for low lead requirement, NSF/ANSI 42 and NSF/ANSI 58 for material safety and structural integrity.

Model: CulRF-M5 used in devices ClearLink™ PB, ClearLink™ D-WiFi, ClearLink™ D, ClearLink™ AQ, and ClearLink™ AQ PB.
WM-N-BM-30 used in device ClearLink™ D-WiFi.

Contains FCC ID: V7U-010330CL, IC: 6510B-010330CL,
FCC ID: COF-WMNBM30 and IC: 10293A-WMNBM30.

This device complies with part 15 of the FCC Rules subject to the following two conditions: (1) This device may not cause harmful interference (2) This device must accept all interference received including interference that may cause undesired operation.

Le présent appareil est conforme aux CNR Innovation, Sciences et Développement économique Canada applicables aux appareils radio exempts de licence. L'exploitation est autorisée aux deux conditions suivantes : (1) l'appareil ne doit pas produire de brouillage, et (2) l'utilisateur de l'appareil doit accepter tout brouillage radioélectrique subi, même si le brouillage est susceptible d'en compromettre le fonctionnement.

This device complies with Health Canada's Safety Code. The installer of this device should ensure that RF radiation is not emitted in excess of the Health Canada's requirement.

Cet appareil est conforme avec Santé Canada Code de sécurité 6. Le programme d'installation de cet appareil doit s'assurer que les rayonnements RF n'est pas émis au-delà de l'exigence de Santé Canada.

Changes or modifications not expressly approved by the party responsible for compliance could void the user's authority to operate the equipment.

Les changements ou modifications non expressément approuvés par la partie responsable de la conformité pourraient annuler l'autorité de l'utilisateur à utiliser cet équipement

This equipment has been tested and found to comply with the limits for a Class B digital device, pursuant to part 15 of the FCC Rules. These limits are designed to provide reasonable protection against harmful interference in a residential installation. This equipment generates, uses and can radiate radio frequency energy and, if not installed and used in accordance with the instructions, may cause harmful interference to radio communications. However, there is no guarantee that interference will not occur in a particular installation. If this equipment does cause harmful interference to radio or television reception, which can be determined by turning the equipment off and on, the user is encouraged to try to correct the interference by one or more of the following measures:

- Reorient or relocate the receiving antenna.
- Increase the separation between the equipment and receiver.
- Connect the equipment into an outlet on a circuit different from that to which the receiver is connected.
- Consult the dealer or an experienced radio/TV technician for help.

This device complies with Innovation, Science and Economic Development Canada's licence-exempt RSS standard(s). Operation is subject to the following two conditions: (1) this device may not cause interference, and (2) this device must accept any interference, including interference that may cause undesired operation of the device.

Le présent appareil est conforme aux CNR Innovation, Sciences et Développement économique Canada applicables aux appareils radio exempts de licence. L'exploitation est autorisée aux deux conditions suivantes : (1) l'appareil ne doit pas produire de brouillage, et (2) l'utilisateur de l'appareil doit accepter tout brouillage radioélectrique subi, même si le brouillage est susceptible d'en compromettre le fonctionnement.

This Class B digital apparatus complies with Innovation, Science and Economic Development Canada ICES-003.

Cet appareil numérique de la classe B est conforme à la norme NMB-003 du Innovation, Sciences et Développement économique Canada.



About this Manual

This manual:

- Familiarizes the operator with the equipment
- Explains installation and setup procedures
- Explains the various modes of operation
- Gives specifications and troubleshooting information

This publication is based on information available when approved for printing. Continuing design refinements could cause changes that may not be included in this publication.

Safe Practices

Throughout this manual there are paragraphs set off by special headings.

Note

Notice is used to emphasize installation, operation or maintenance information which is important, but does not present any hazard. For example,

NOTE The nipple must extend no more than 1 inch above the cover plate.

Caution

Caution is used when failure to follow directions could result in damage to equipment or property. For example,



CAUTION! Disassembly while under water pressure can result in flooding.

Warning

Warning is used to indicate a hazard which could cause injury or death if ignored. For example,



WARNING! Electrical shock hazard!
Unplug the unit before removing the timer mechanism or cover plates!

The CAUTION and WARNING paragraphs are not meant to cover all possible conditions and situations that may occur. It must be understood that common sense, caution, and careful attention are conditions which cannot be built into the equipment. These MUST be supplied by the personnel installing, operating, or maintaining the system.

Be sure to check and follow the applicable plumbing codes and ordinances when installing this equipment. Local codes may prohibit the discharge of acid or caustic solutions to drain. An extra solution tank should be used to neutralize the solution before discharging to drain.

Use protective clothing and proper face or eye protection equipment when handling chemicals or power tools.

Serial Numbers

The serial number is located on the back of the control box.

This publication is based on information available when approved for printing. Continuing design refinement could cause changes that may not be included in this publication.

NOTE Do not remove or destroy the serial number.
It must be referenced on request for warranty repair or replacement.

About Models

ClearLink™ PRO

The ClearLink™ PRO is a first-to-market wireless control system that allows you to get Culligan® filtered water from your main faucet. Installing an RO system used to require a dedicated faucet, which meant drilling a hole or losing a soap dispenser. Now you can use your existing faucet to wash vegetables with your sprayer, fill pots for cooking, or simply enjoy a glass of filtered water.

NOTE Illustrations are for overview purposes only, for RO installations an air gap and RO tank is needed.

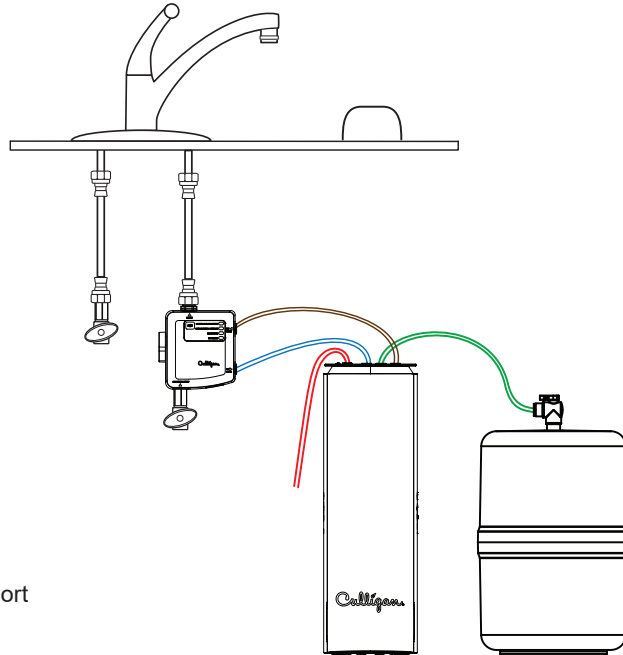

- Outlet to ClearLink top side port
- Outlet to tank
- Inlet from ClearLink bottom side port
- Outlet to air gap

ClearLink™ Connect

The ClearLink™ Connect takes the ease of using your current faucet and pairs it with the technology of staying connected anywhere. This Wi-Fi enabled ClearLink keeps all of the same functionality of the ClearLink PRO but adds the ability to connect to the Culligan Connect App. Track water consumption, contaminants being removed, filter / membrane life and if a leak is detected from anywhere, using the convenience of an app.

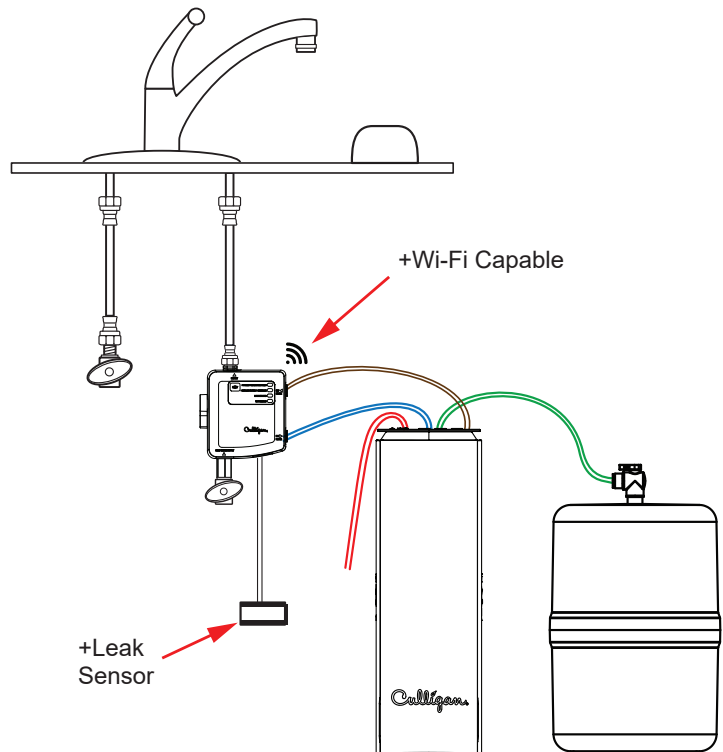

- Outlet to ClearLink top side port
- Outlet to tank
- Inlet from ClearLink bottom side port
- Outlet to air gap

Drinking Water Connect

NOTE Separate connections for filtered and unfiltered water.

The Drinking Water Connect allows drinking water customers to stay connected to their system anywhere. This Wi-Fi enabled product can be added to virtually any household drinking water installation and adds the ability to connect to the Culligan Connect App. Track water consumption, contaminants being removed, filter / membrane life and if a leak is detected from anywhere, using the convenience of an app.

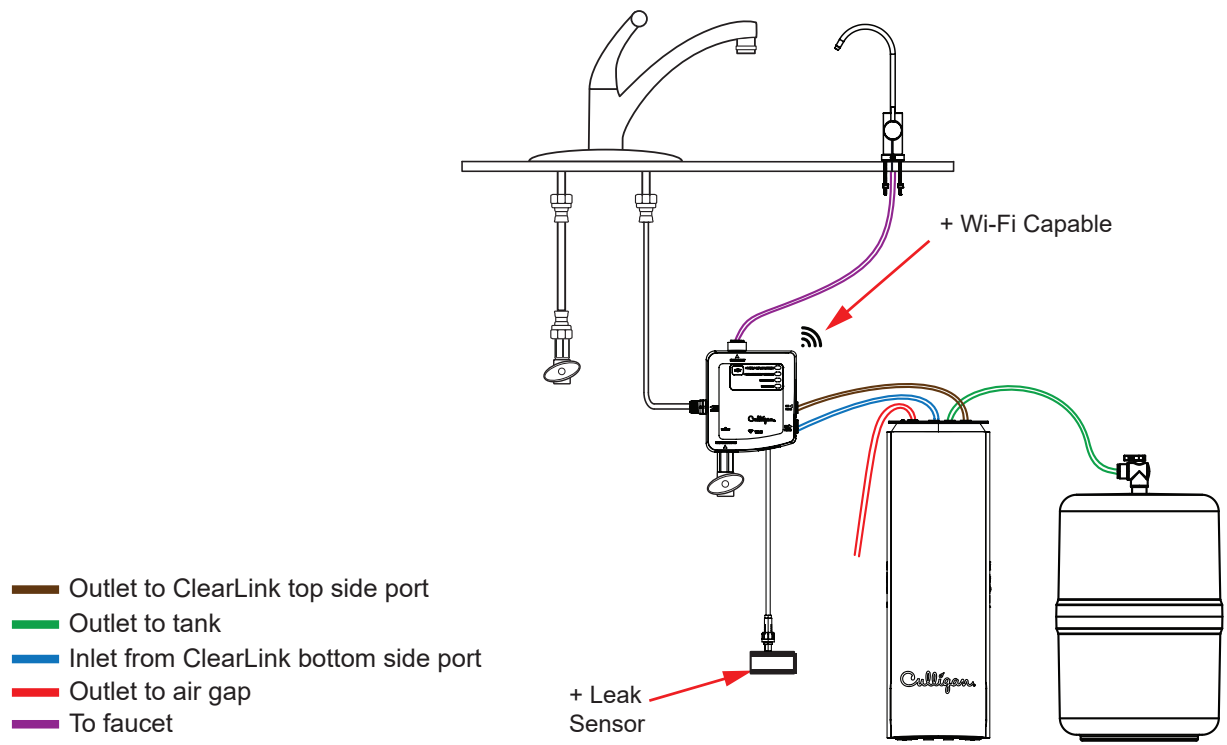

Aquasential® ClearLink™ PRO

The Aquasential® ClearLink™ PRO is specifically designed to work with our new Aquasential® Smart RO, the most efficient RO drinking water system available. This version of the ClearLink allows you to keep the great features of the ClearLink PRO all while being integrated directly into your Smart RO system, giving you more information at your fingertips.

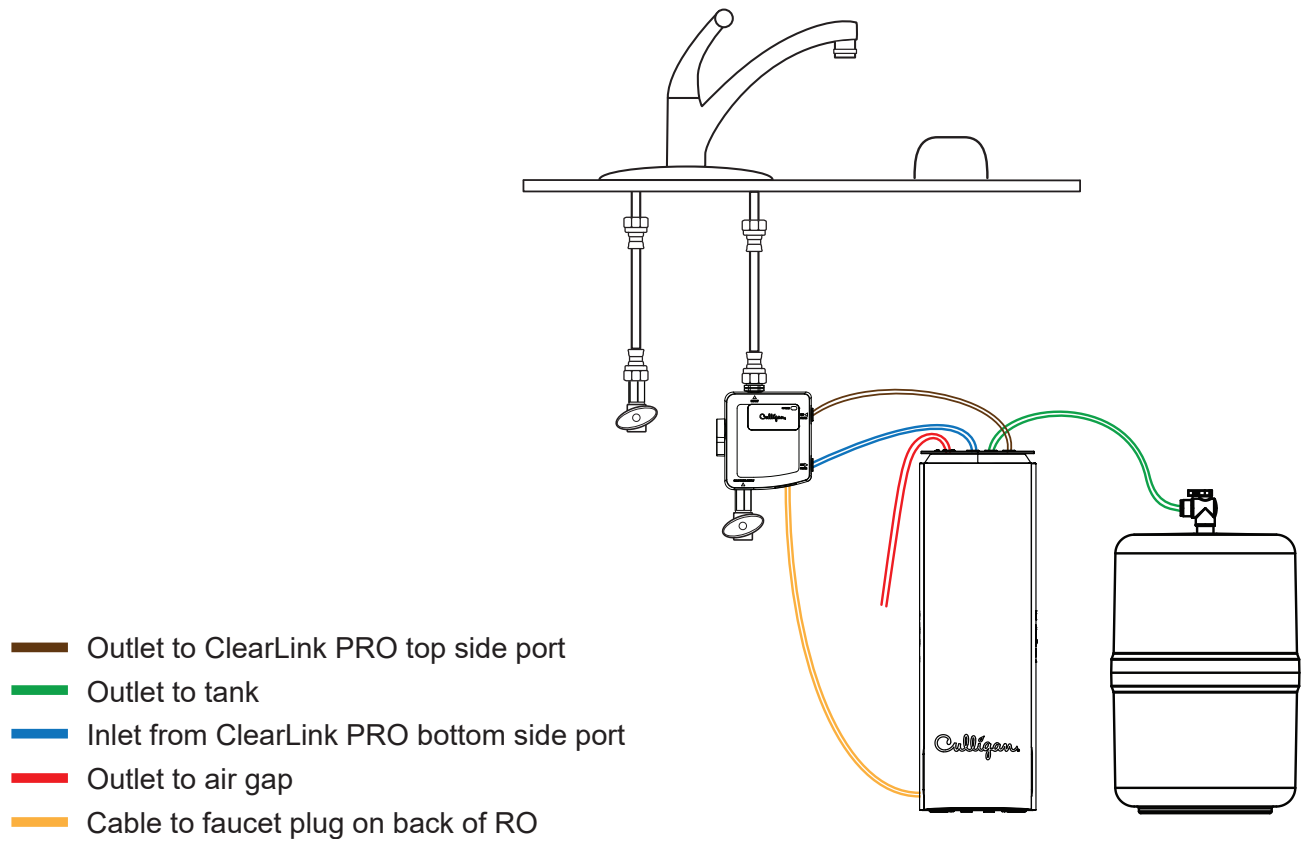

Installation

Parts Included:

- Remote Button (not available with Drinking Water Connect)
- Control Box
- Battery Box
- 3/8" x 1/4" Tube Adapter
- Mounting Screws
- Air Gap and Installation Bracket (not available with Drinking Water Connect)

Tools and Materials Required

- D Batteries x4 (not required for Aquasential ClearLink PRO)
- AAA Batteries x2
- Screwdriver
- Adjustable Wrench
- Towels
- Pan or Bucket

Specifications

Pressure Range: 30-120 psi (207-827 kPa)

Temperature Range: 40-100° F (4.4 - 37.7° C)

Precautions



WARNING! Follow all precautions indicated in the manual provided with the Culligan water treatment system.

WARNING! For systems using a booster or distribution pump, the pressure of the treated water cannot exceed the pressure of the cold water supply.

WARNING! Reducing the Booster pump pressure below incoming pressure will allow the proper operation of the ClearLink.

WARNING! For cold water use only. Do not use on hot water line.



CAUTION! Control box must be protected against freezing temperatures, frost, snow, sleet and ice. Exposure to these can produce cracks and product failures.

CAUTION! The Filter/RO should be flushed before installing into the system to ensure the proper operation of the ClearLink.

CAUTION! This product has a limited service life. We recommend that a record be kept regarding the date of install and any other performed maintenance. Because of the product's limited service life and to prevent costly repairs or possible water damage, we strongly recommend that the control box be replaced every ten years.

- After prolonged periods of non-use (such as during a vacation) it is recommended that the system be flushed thoroughly. Let the filtered water run for 5-6 minutes at 1.6 gpm before using.
- The ClearLink estimates filter life based on flow and time. Changes in taste, odor, color and/or flow of the filtered water could indicate that the filter(s) should be replaced.
- Make certain that installation complies with all state and local laws and regulations.

Setting Capacity and TDS Function (All Models)

NOTE This section does not apply to Aquasential ClearLink PRO

Find the dip switches on the front of the circuit board. SW2 and SW3 set the time and capacity for the filter reminder. Default settings for the dip switches are TDS ON, 1000 gallons and 365 days.

- SW1: Enables/Disables the TDS function (Enable only for RO systems). The system will measure the difference between the feed and product water to determine if the RO is working. If installing an RO system with a Mineral Boost cartridge, this feature may need to be disabled so that the alert indicator does not illuminate prematurely for RO membrane replacement.
- SW2: Filter capacity in gallons.
- SW3: Filter capacity in days.
- SW6: Used for production testing and should be left in the off position.

If dip switches are changed from the default positions, you must press and hold the RESET button to ensure filter capacity is counted correctly.

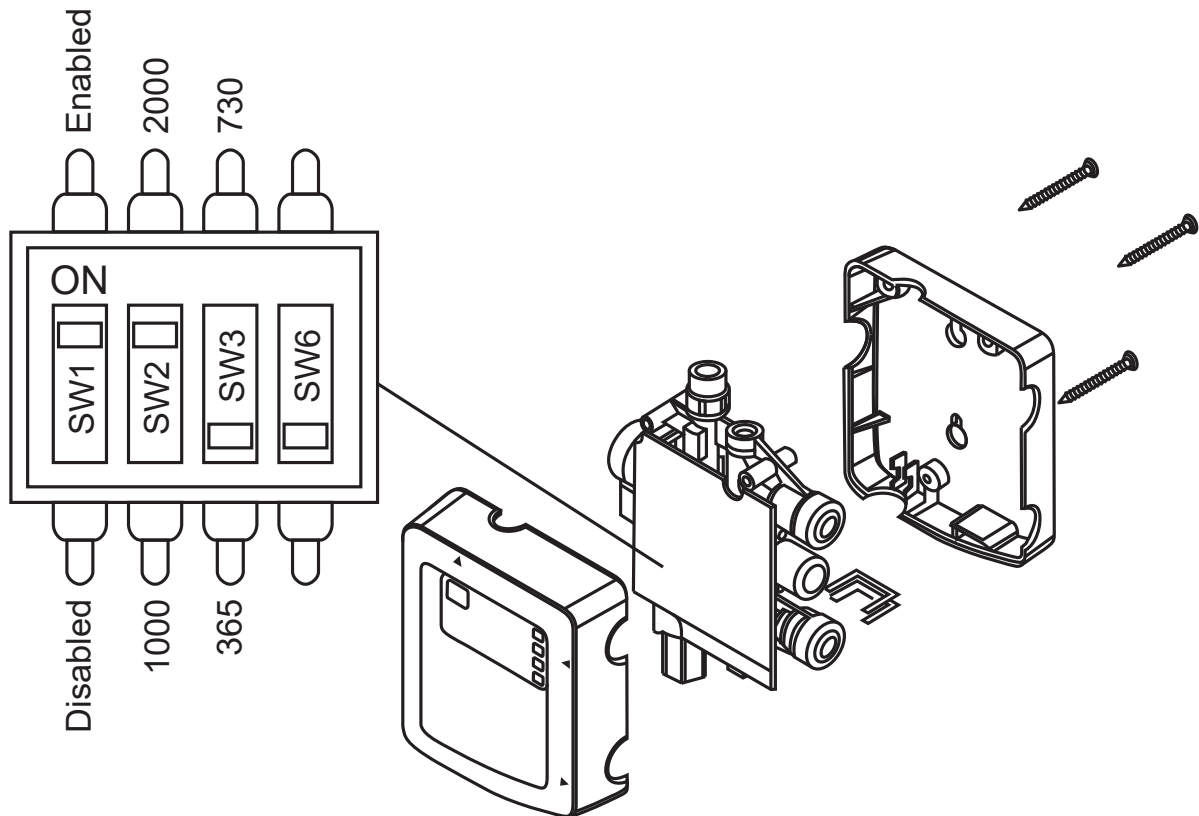

NOTE Set capacity and TDS function before starting installation.

NOTE To access the dip switches for setting capacity and TDS function, open the control box by removing the three screws in the rear cover.

NOTE No combination of SW2 and SW3 positions will disable either setting. The alarm and/or notification for filter replacement will always alert based on whichever capacity setting is reached first. Therefore, it is also not possible to force the system to only alert based on ONE setting.

Installation (All Models)

NOTE If using an external flow switch, install the external flow switch before installing the ClearLink. See "[External Flow Switch for a Secondary Outlet](#)" on page 16 for instructions.

NOTE Refer to the manual provided with your filter/RO for installation instructions specific to that system.

NOTE Some installations may require adapters and fittings not included with the product. Review the manual and your installation before beginning.

NOTE Consult your local plumbing codes and install accordingly.

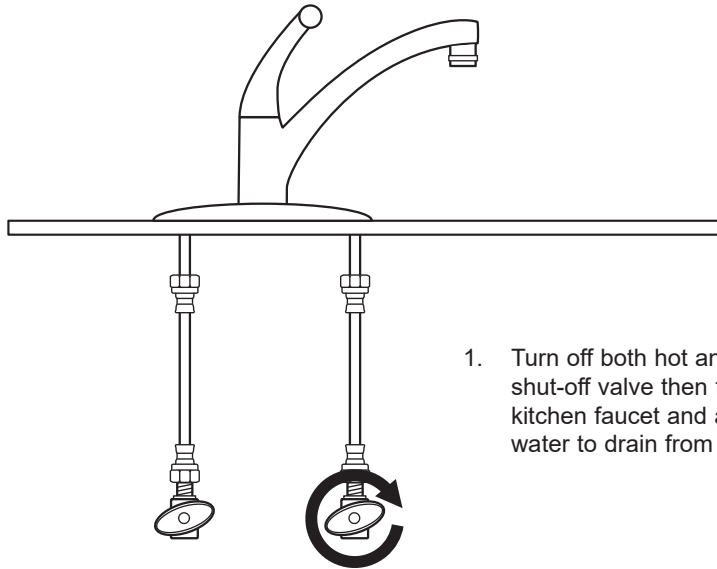

1. Turn off both hot and cold water shut-off valve then turn on the kitchen faucet and allow all water to drain from line.

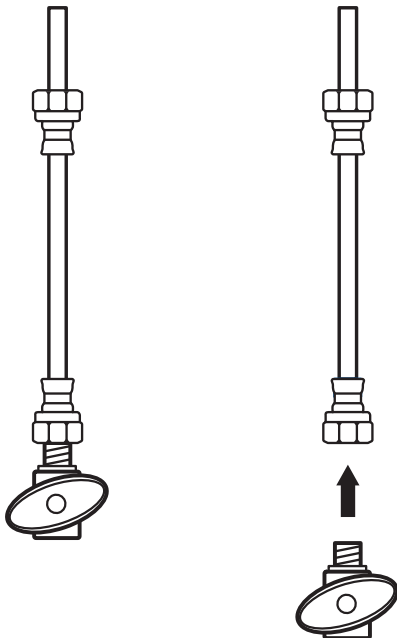

2. Disconnect the cold water line from the cold water shut-off valve.

NOTE If rigid plumbing pipe (metal or plastic) is used, you may need to shorten the pipe using a hacksaw or pipe cutter to accommodate the control box.

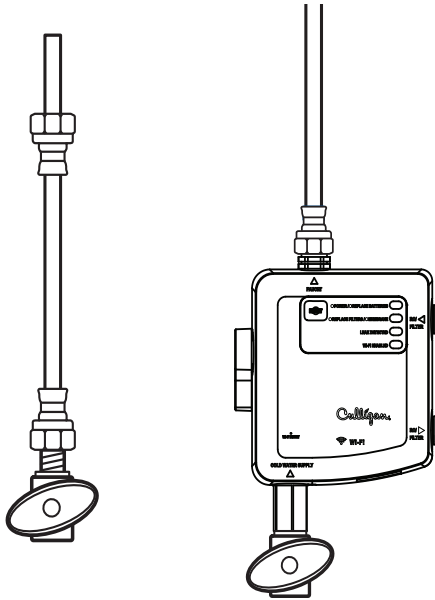

3. Connect the control box to the cold water shut-off valve and the water line to the Faucet as shown. Culligan recommends 1/2 - 3/4 additional turns past finger-tight.



CAUTION! The stationary hex nut on the outlet of the ClearLink should not be used to over-tighten the hose fitting.

4. Connect the inlet on the RO/Filter system to the port marked "RO/Filter ▶." Wet the end of the plastic tubing with water and push it into the quick connect fitting adapter approximately 5/8" until it stops.

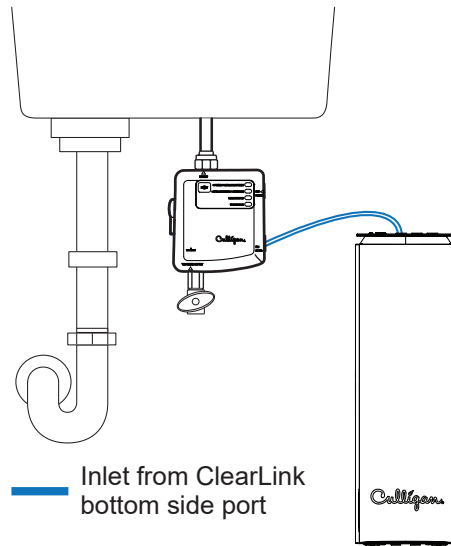

NOTE The control box must be in a vertical position.

NOTE If space does not allow for mounting the control box onto the valve, it can be mounted on a wall and connected using flexible lines. (purchased separately).

NOTE Flare fittings used on cut-to-fit PEX line prevent the connecting nut from being threaded on more than 1-2 turns. Therefore, it is recommended that the MS031611 adapter listed in the "Installation Fittings and Replacement Parts List" section be used. The flare fitting of the PEX line should be cut off and the tubing inserted directly into the push-to-connect end of the MS031611 adapter.

NOTE All filters and RO membranes should be flushed before connecting any ClearLink device to the filtration/RO system.

NOTE The port marked "RO/Filter" is plugged for remote system installations (Water supply is not the same as the sink such as basement installations). This port is normally plugged when installing the filtration/RO system in a location other than the kitchen cabinet.

NOTE Use the supplied adapter if your system uses a 1/4" tube.

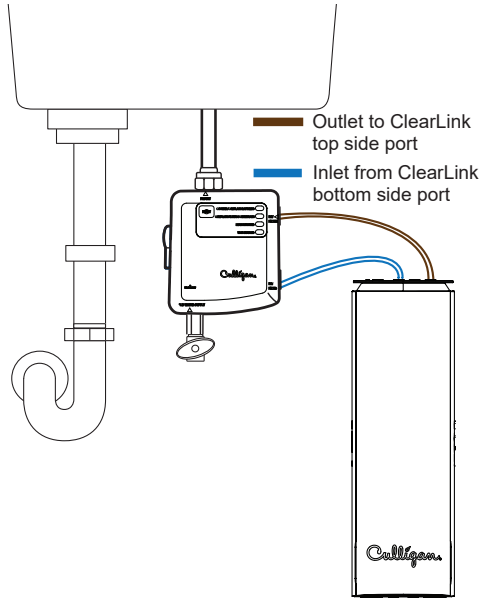

5. Connect the product water outlet on the RO/Filter system to the port marked "RO/Filter ►." Wet the end of the plastic tubing with water and push it into the quick connect fitting adapter until it stops.

NOTE This is the line that would normally go to your dedicated faucet.

NOTE Connect the tank and/or post filter in this line if required for your filter/RO system.

NOTE Steps 6 through 8 are only for RO installations using an air gap.

NOTE If your filtration system is not an RO, skip to System Startup.

NOTE Install the drain connection to the drain plumbing according to the manual provided with your RO system.

NOTE Check and adhere to local plumbing codes for Air Gap installation.

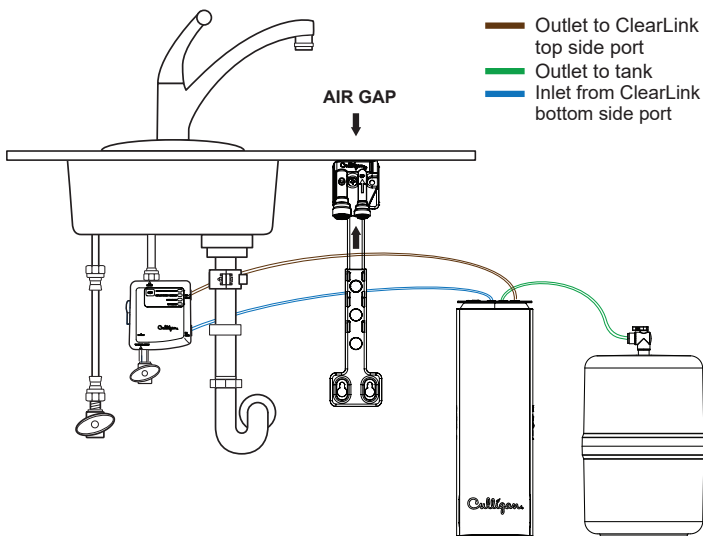

6. Mount the air gap device as near to counter top as possible and in a vertical orientation.

- 6a. The provided installation bracket can be used in order to assist in mounting the air gap as high as possible.

To use: Attach the air gap to the bracket using a single screw. Raise the assembly as high as possible and secure to the cabinet using the bracket's lower mounting points.

WARNING! Install the air gap as high as possible using air gap installation bracket.



WARNING! Failure to mount the air gap device vertically will cause it to leak water.

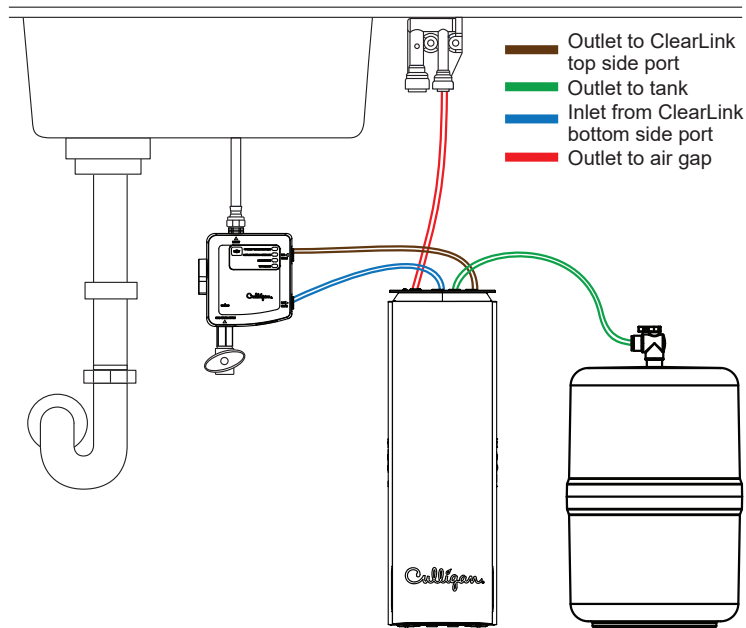

7. Connect the drain line coming from the RO system to the 1/4" connection of the air gap device.

NOTE Drain line adapters are available through Culligan Marketplace that can be used when considering the best drain line connection.

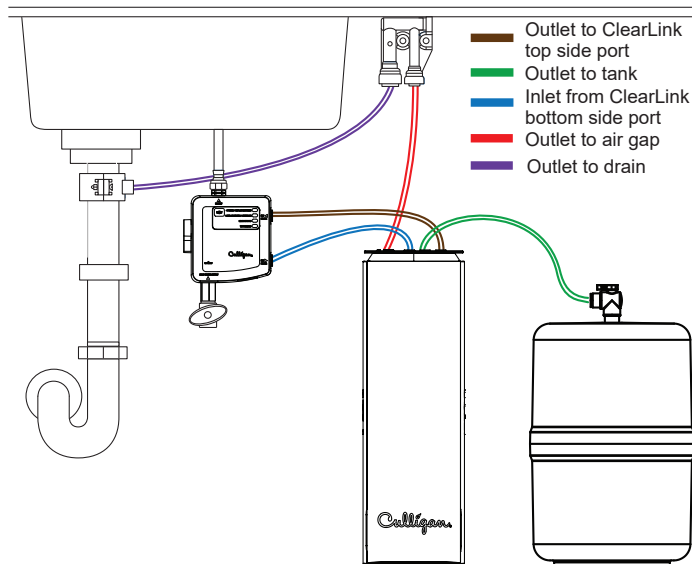

8. Connect the 3/8" fitting of the air gap device to the connection on the drain plumbing.

NOTE If the customer has a garbage disposal, connect the RO drain line coming from the air gap to the "auxiliary" port (removable plug where a dishwasher drain is typically hooked up) rather than downstream of the disposal. The high flow rate from a disposal sucking water from a clogged sink will send water up and out of the air gap.

External Flow Switch for a Secondary Outlet

For use with ClearLink Connect and as an optional accessory on the Drinking Water Connect.
Not available for use with ClearLink PRO or the Aquasential ClearLink PRO.

See "[Routing Guides](#)" on page 33.

- NOTE** External flow switch must be installed after the post filter.
- NOTE** If the inlet of the refrigerator (or similar) requires 1/4" tubing, the reducing stem should be installed as close to the refrigerator as possible to reduce the pressure drop caused by smaller diameter tubing.
- NOTE** External flow switch is rated to operate between 0.25GPM and 1.32GPM.

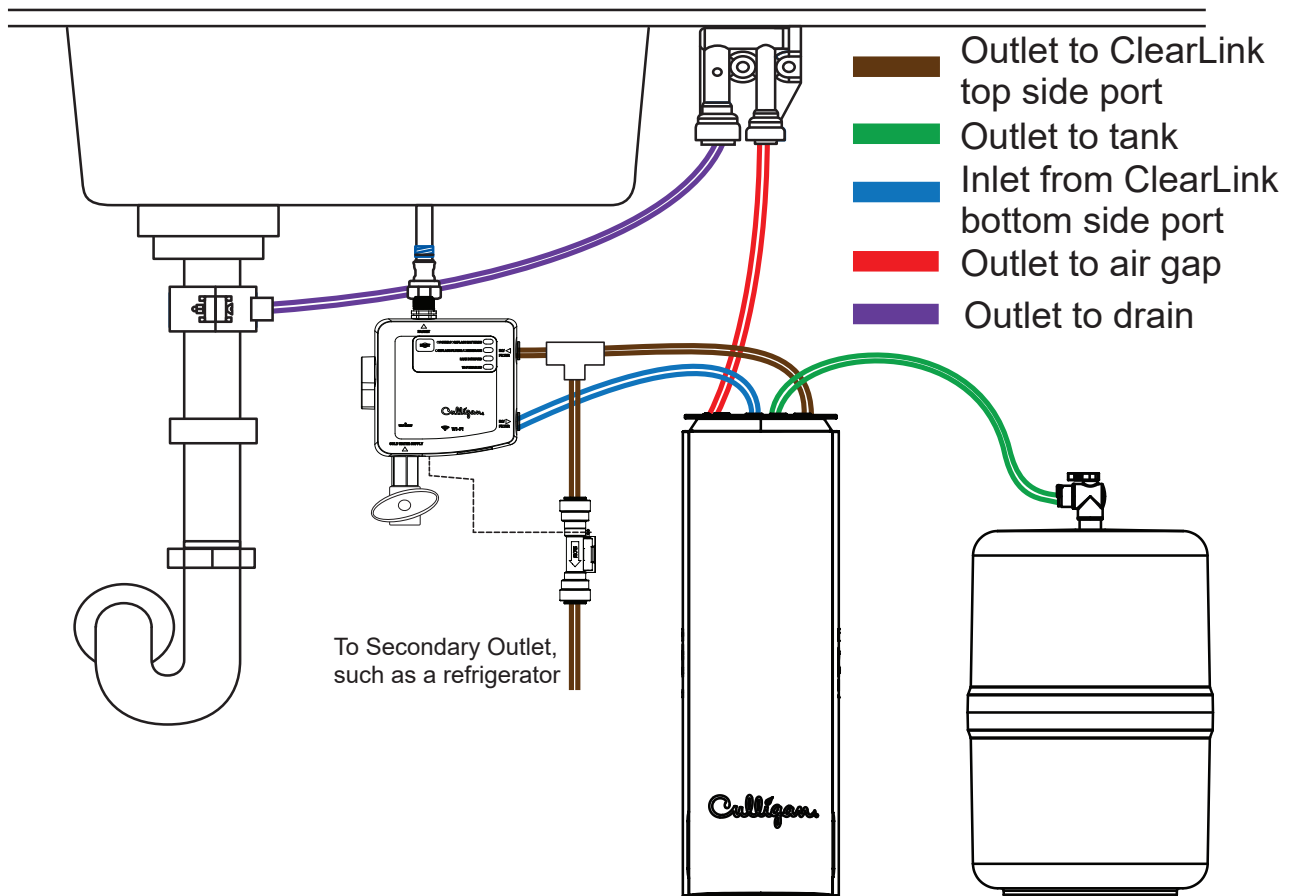

Flow Switch Wiring

NOTE The standard length of the flow switch wire is 3'.
If needed, a 40' wire extension is available separately.

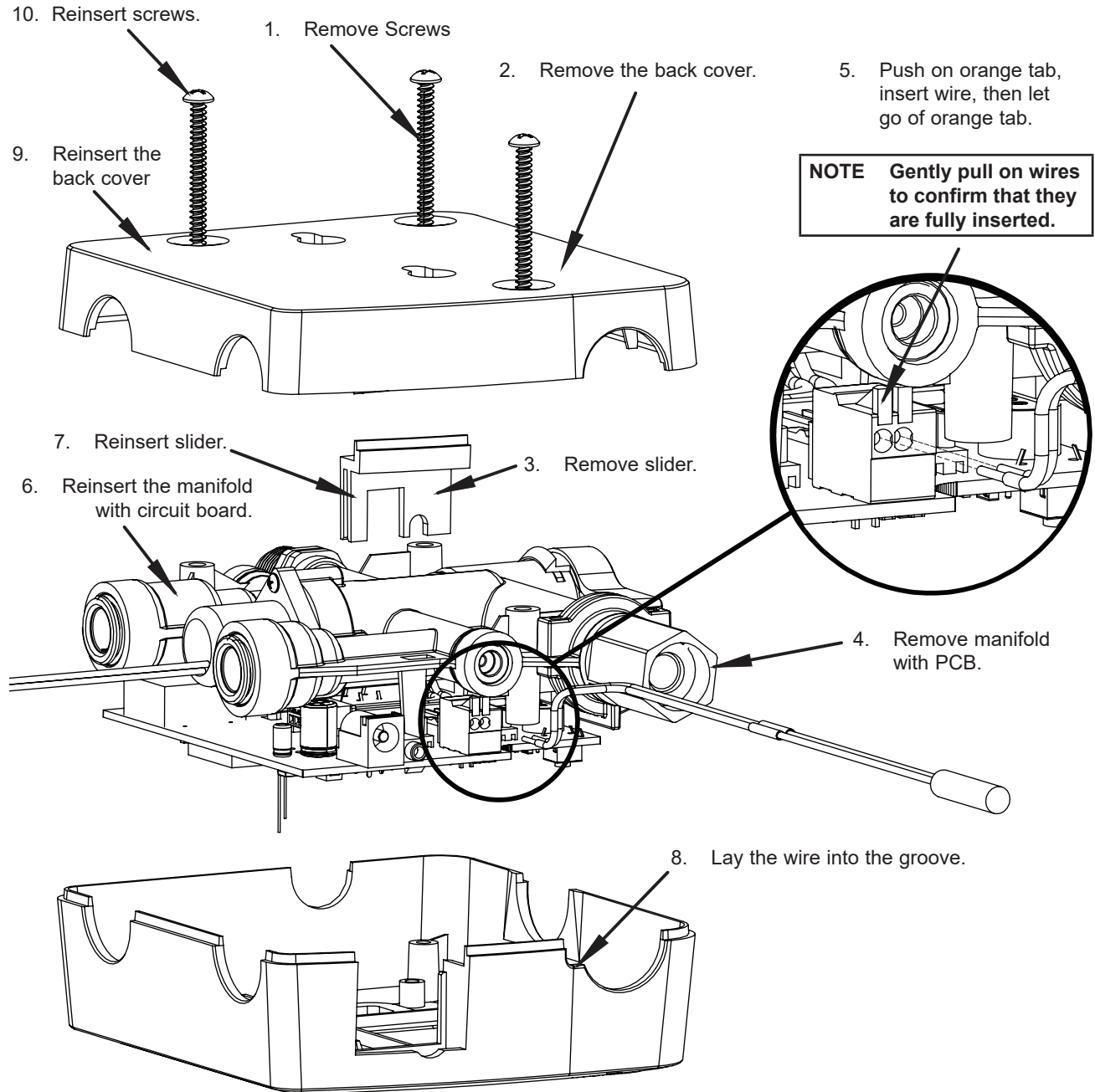

Flow Switch 40' Wire Extension Kit (if applicable)

- Using wire strippers, strip a 1/4" of insulation from the wire.

NOTE Stripping too much of the wire can cause the wires to fray, which can cause the unit to malfunction over time. Stripping too little of the wire can prevent the ends from being able to have proper contact with the connector on the PCB.

- Connect flow switch wires to the extension using the supplied crimp connectors.



- Insert wires into the connector on the PCB, see "[Leak Sensor Installation](#)".

- Cut wire to required length.

Leak Sensor Installation

NOTE For use with ClearLink Connect and Drinking Water Connect.
Not available for use with ClearLink PRO or the Aquasential ClearLink Pro.

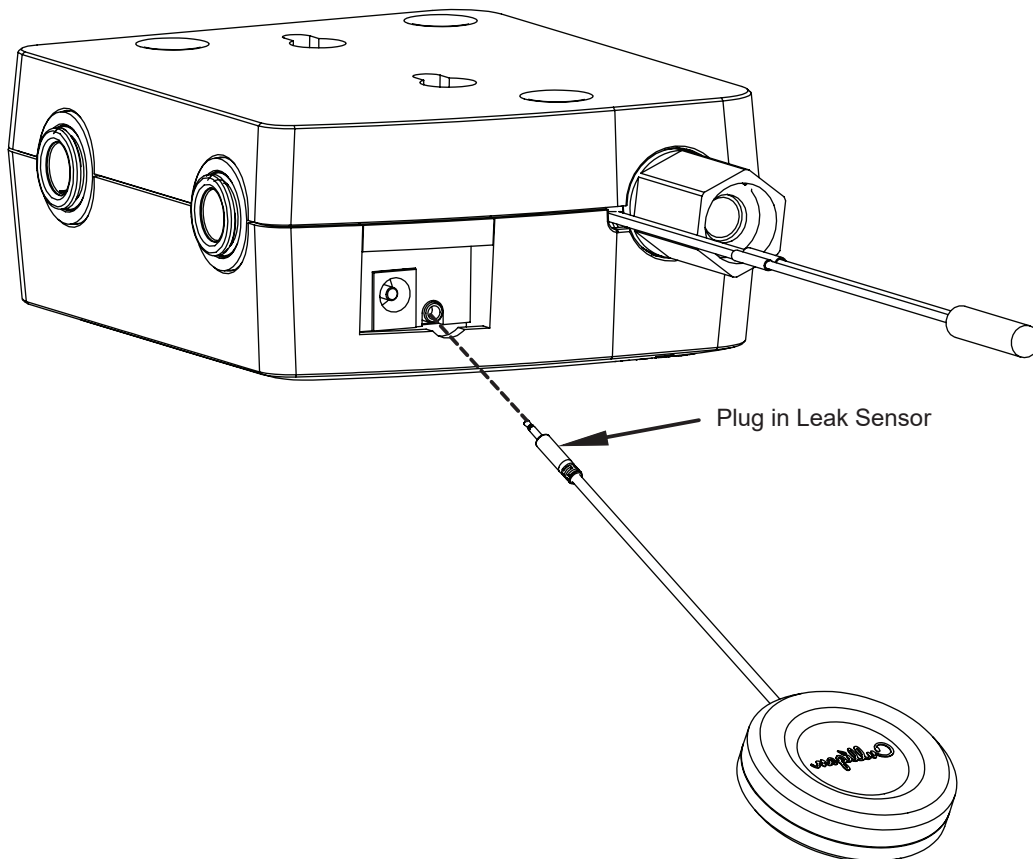

System Startup

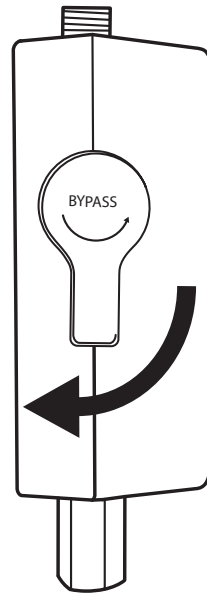

1. Confirm that the bypass valve is in the closed position (pointed down).

NOTE When in the open position, the bypass valve simply allows incoming water to flow straight to the outlet without having to pass through the solenoid junction. When the bypass valve is open, it is possible for treated water to mix with the unfiltered water depending on the supply pressure. See section labeled "Flow Path Diagrams" for further understanding.

Figure 1. Bypass Valve

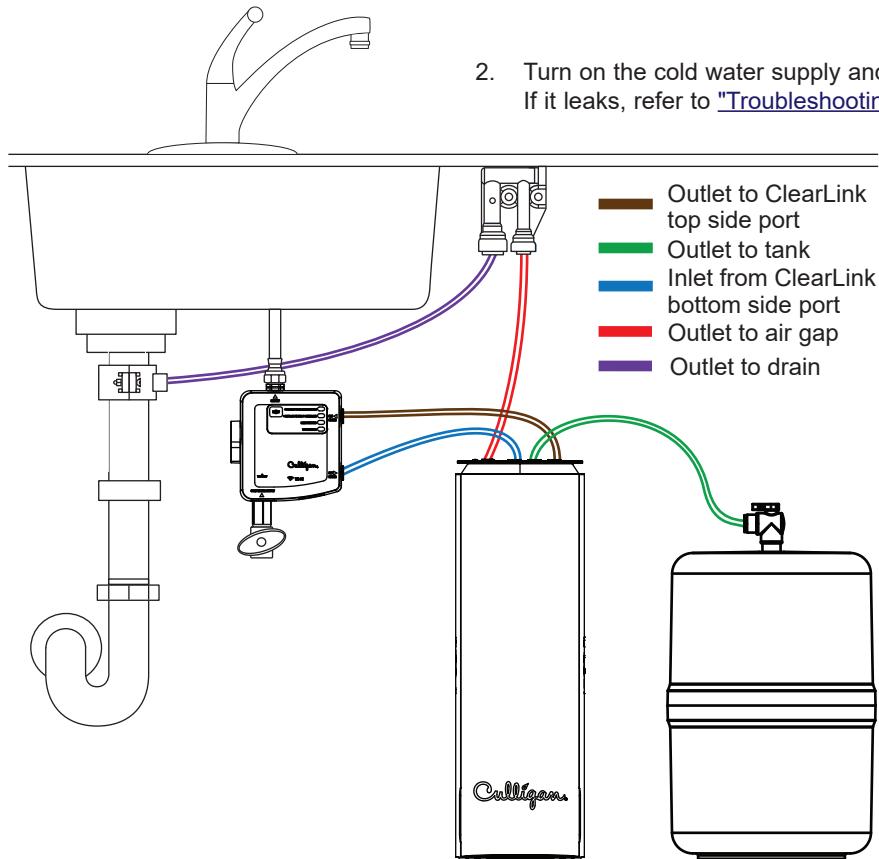

2. Turn on the cold water supply and check for leaks. If it leaks, refer to ["Troubleshooting" on page 28](#).

Figure 2.

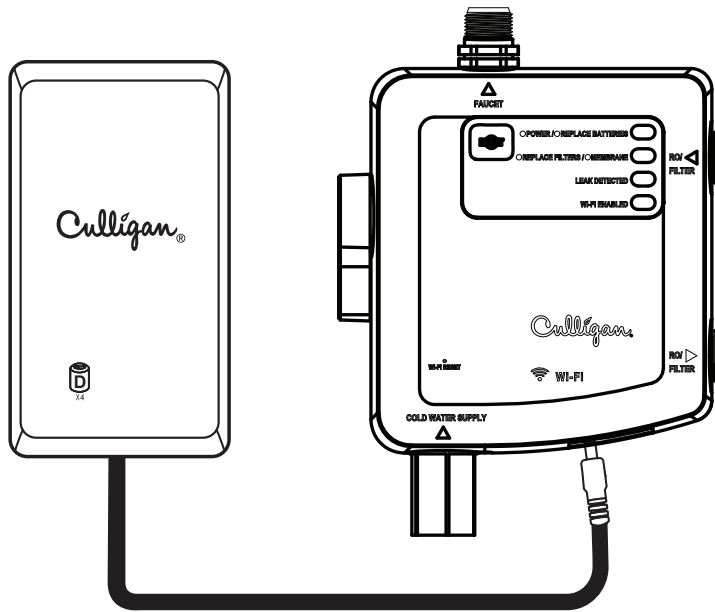

3. Install four D batteries (not included) into the battery box and plug into the jack on the bottom of the control box.

- | | |
|-------------|--|
| NOTE | The control box will beep and flash the power light when powering up. |
| NOTE | AC adapter (01029455) can also be used where a non-switch-controlled outlet is available. |
| NOTE | The Aquasential ClearLink PRO receives its power from the Aquasential Smart RO. See Figure 4 for connection point. |

Figure 3. Battery Box

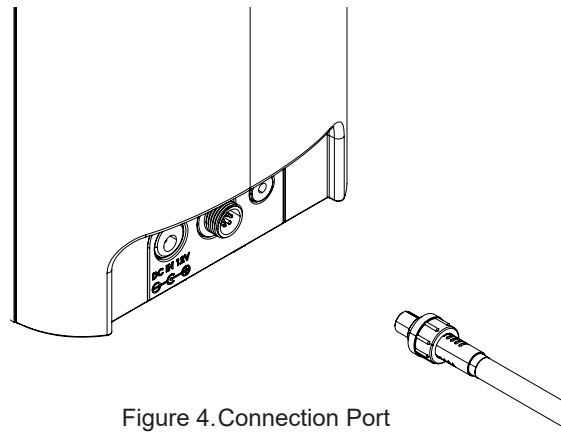
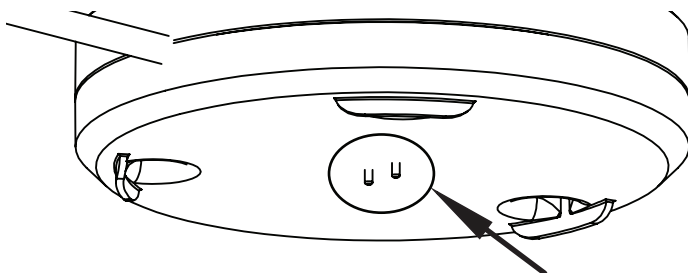
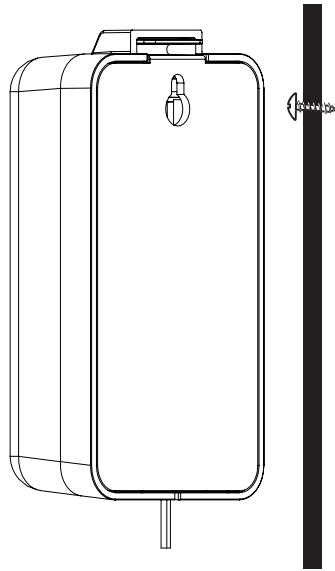

Figure 4. Connection Port



4. Place a damp paper towel to the pins. This should cause the leak sensor light on the control box (page 19) to flash, the unit to beep and the Culligan Connect App (if setup) to notify the user of the error.
5. Dry pins and place at the lowest point in the cabinet or under the ClearLink Control Box.

Figure 5. Test Leak Sensor



6. Use the provided screw to hang the battery box on the side of the cabinet.

Figure 6. Hang Battery Box on Side of Cabinet



7. Install two AAA batteries (not included) into the remote button.
- 7a. Burp air after assembling battery cover. To relieve air, lift back one edge of the base, press center of rubber down, release edge.
8. Turn on the faucet to full cold and push the button to activate the system.

Figure 7. Install Batteries in Remote Button

Button Display Guide

ClearLink Button Display

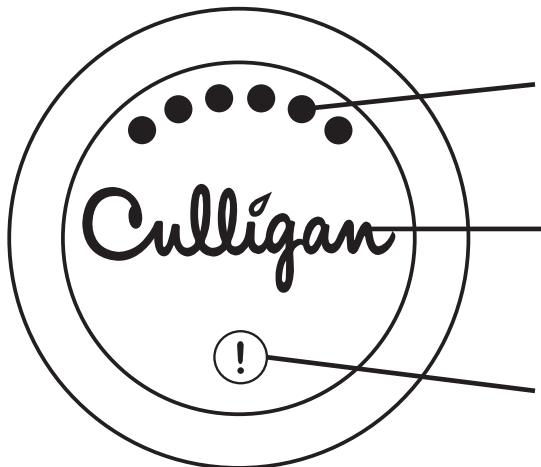

Filter Capacity Lights: Shows from 1-6 lights depending on filter capacity remaining, 6 lights => 80% and 1 light =<10%.

Culligan Logo: Flashes when treated water is not available from the faucet. Stays solid while treated water is being dispensed from the faucet.

Alert Indicator: Illuminates when the control box batteries need replacing, filters need replacing, membrane needs replacing or if leak is detected on connected versions.

NOTE All filters and RO membranes should be flushed before connecting any ClearLink device to the filtration/RO system.

NOTE The blue capacity lights should appear if the button and control box are communicating.

NOTE The button can be turned off with a second push or by turning off the faucet.

Aquasential ClearLink PRO Button Display

Bottom icons

- Wi-Fi and Alert icon only illuminate if there is an issue
- TDS and battery (if installed) light when the faucet is being used

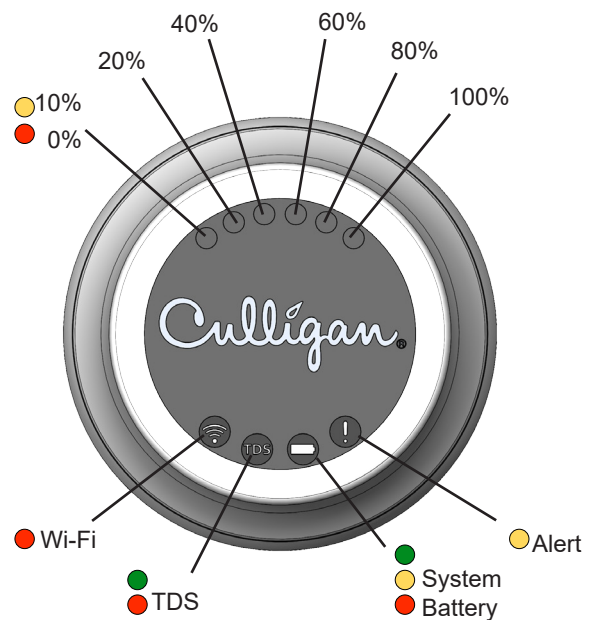

Control Box Operation

ClearLink™

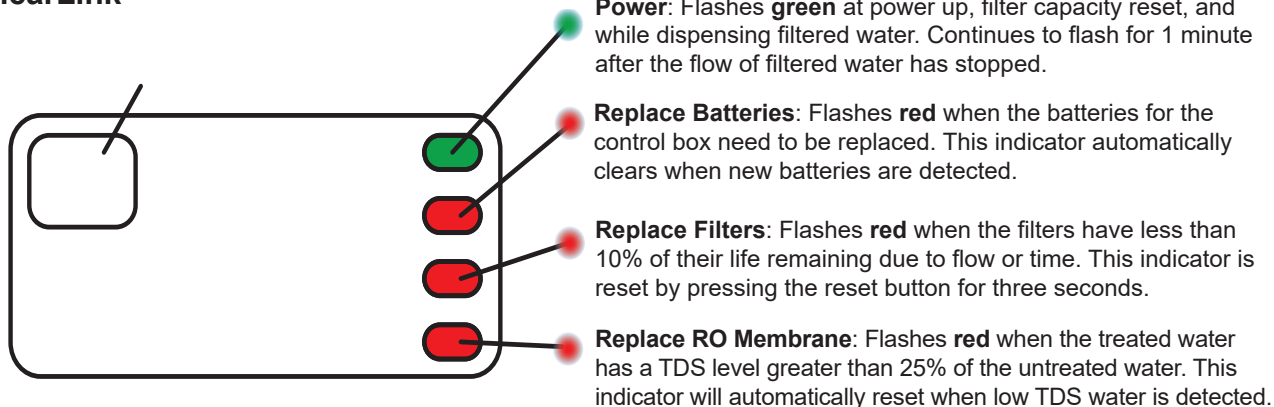

ClearLink™ Connect and Drinking Water Connect

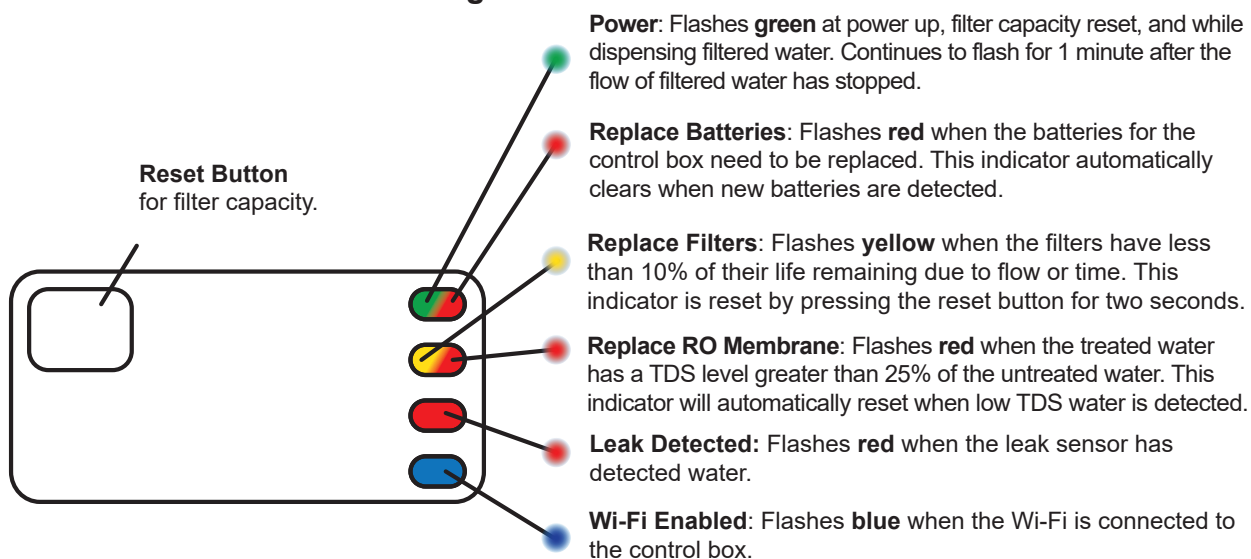

Aquasential ClearLink™ PRO

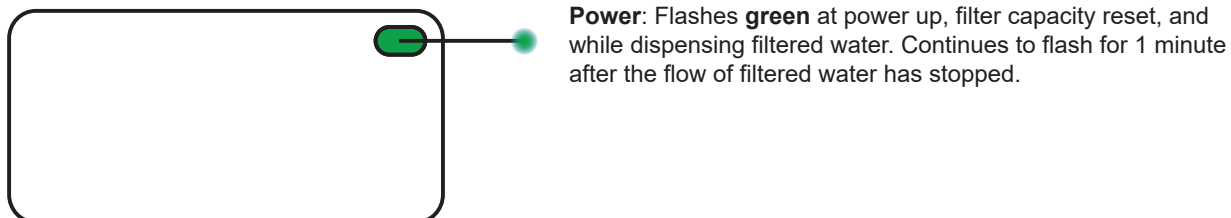

Pairing to Smart Device



Culligan Connect App Installation for Aquasential® ClearLink™ PRO

Refer to the Aquasential® RO and Smart RO Advanced Drinking Water Systems installation manual on C-Port for instructions (P/N 01040604).

Culligan Connect App Installation for all other ClearLink™ products

NOTE This section is only applicable to the ClearLink Connect and Drinking Water Connect

Pair to Android

1. Download and install “Culligan Connect” app from the Google Play Store to the customer’s smart device.
2. Log in if the customer has an existing Culligan Connect app or create a new account if they do not.
3. Verify through the email on the customer's tablet/phone.
4. Once logged in, tap “add system” and follow the prompts.

NOTE You will have a 24 hour window to confirm the account.

Wi-Fi Reset Button:

Press with paper clip.

One short press forces data upload.

Holding for 10 seconds will initiate device pairing.

5. To activate device and place it into pairing/registration mode, use a paper clip to press and hold Wi-Fi Reset on the Control Box for 10 seconds until blue light changes from flashing to solid.

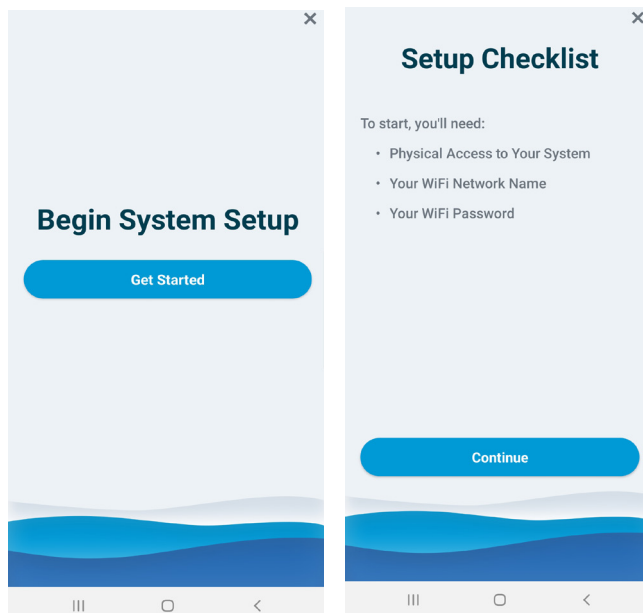
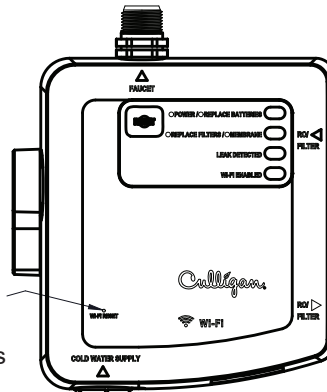

6. Start system setup process.

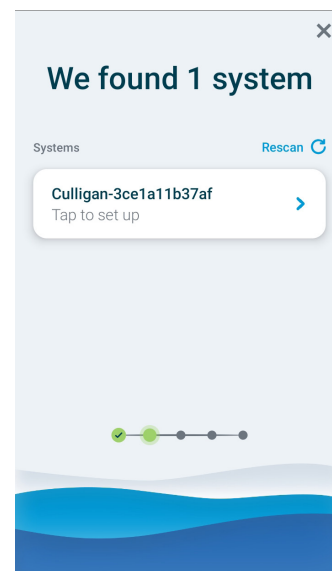

7. Search for Culligan device and select it once found.

8. Select your local Wi-Fi network, enter Wi-Fi password (if applicable) and connect device.
9. Using a paper clip, press and release the Wi-Fi Reset to complete setup (the Wi-Fi LED will begin flashing).

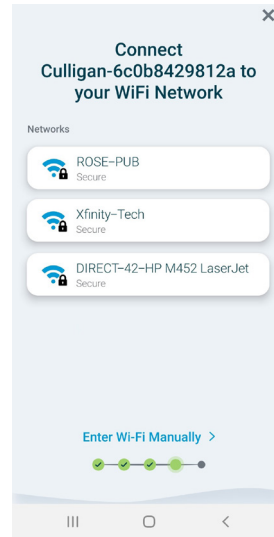

10. Your App and device will now pair.

11. You are now connected and ready to take control of your water!

NOTE Only one account will work per connected ClearLink.

Pair to iPhone or iPad

1. Go to Apple's App Store to download and install "Culligan Connect" app to the customer's smart device.
2. Go to device settings and connect to their local Wi-Fi network.
3. Launch Culligan Connect App.
4. Create a new account by selecting "Create an account".
A link will be emailed to them that must be clicked via their device to finalize setup. Once finalized, log in.

NOTE You will have a 24 hour window to confirm the account.

Wi-Fi Reset Button:

Press with paper clip.

One short press forces data upload.

Holding for 10 seconds will initiate device pairing.

5. To activate device and place it into pairing/registration mode, use a paper clip to press and hold Wi-Fi Reset on the Control Box for 10 seconds until blue light changes from flashing to solid.

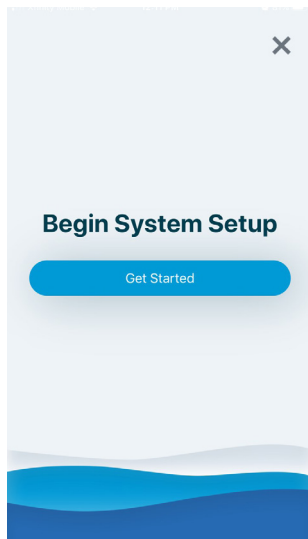
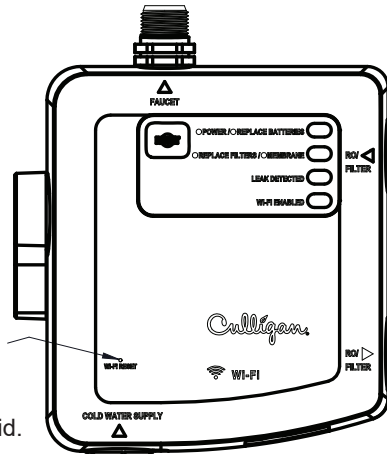

6. Start system setup process.

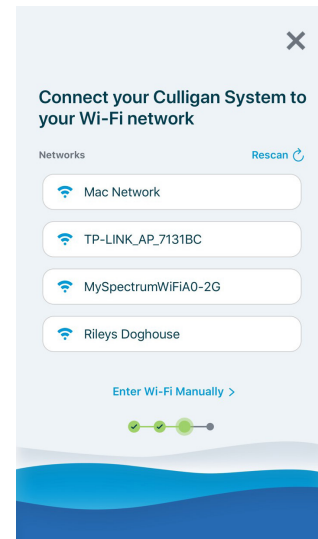
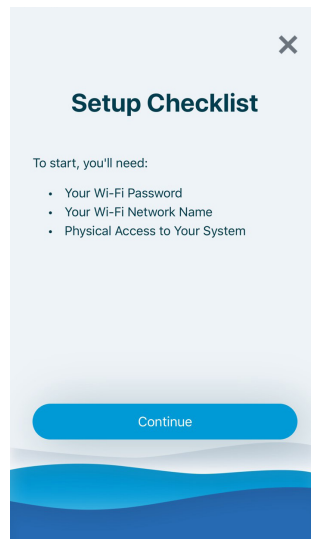

7. Search for Culligan device and select it once found.

8. Select the customer's local Wi-Fi network, enter Wi-Fi password (if applicable) and connect device.
9. Using a paper clip, press and release the Wi-Fi Reset to complete setup (the Wi-Fi LED will begin flashing).
10. The app and device will now pair.
11. The customer is now connected and ready to take control of their water!

NOTE Only one account will work per connected ClearLink.

Viewing Device On C-Port

To ensure you are able to monitor your device on C-Port you must enter your dealer number within the app.

1. Select settings icon in upper corner of home screen.

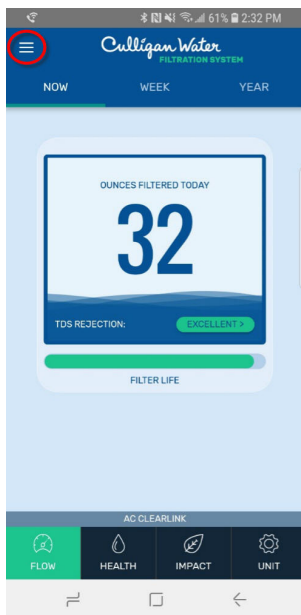

2. Select "Settings" at bottom of the screen.

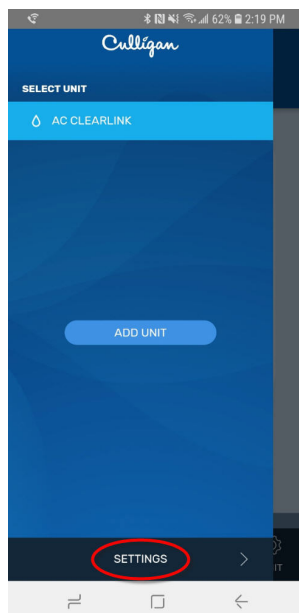

3. Select "Dealer" tab and enter your dealer id # and tap "Change Dealer."

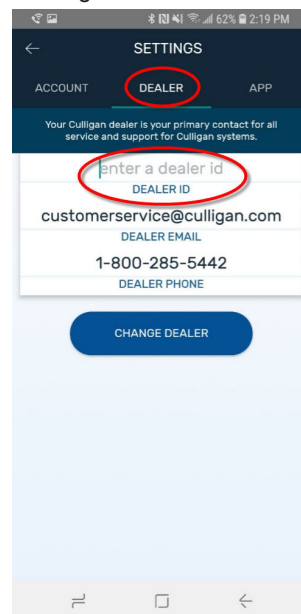

Troubleshooting

Best Practices for Installations

Follow these suggestions as you install and service the ClearLink models for the best results,

- Ensure the button is burped following battery cover assembly.
- To make battery cover installation and removal easier, apply Dow Corning 200 lubricant as needed.
- Power
 - If possible, use the optional 01029455 AC Adapter instead of batteries for the installation. Note that this adapter is only for use with the ClearLink PRO, ClearLink Connect and Drinking Water Connect.
 - Using name brand high-quality alkaline batteries can greatly extend battery life and product functionality.
 - On "ClearLink Connect versions" consider using the power save mode as this will send an update once every 24 hours.
- Test unit operation, re-installation, to ensure you will not have any issues with space constraints or communication between the button and manifold
- Install the air gap using straight, short-as-possible runs of the gravity drain tubing. Locate the drain connection away from the disposal to reduce the likelihood of leaks or blockages.
- The control box needs to be installed as vertically plumb as possible for the solenoid to work properly
- If you have height / space constraints under the sink you can always install on the side cabinet using braided hoses or tubing with the installation adapters
- Use braided flex hoses to make your connections. Avoid using compression nuts and ferrules at the outlet fitting. When needed, use the push fitting adapter for PEX or LLDPE Polyethylene Tubing
- Use care when starting the threads on the plastic outlet fitting to avoid cross-threading or damaging the threads. Do not overtighten.
- Do not rinse any filter, including the post carbon filter, through the control box as it could cause clogging issues in the solenoid or check valve. Pre-rinse all cartridges first
- Flushing or rinsing the cold water line to the sink could help remove debris loosened during the installation and avoid it getting trapped in the solenoid which could affect its operation
- The low voltage limit for the control box batteries is 4.75VDC; if the system detects a voltage at or below this level the low voltage alerts will activate. During service, the current voltage level of the batteries can be checked using a Voltmeter or multimeter by unplugging the battery box from the ClearLink control box and measuring the voltage at the barrel connector. The center of the connector is +VDC and the outer surface is the -VDC terminal. See "Figure 8. Battery Voltage Measurement" for reference.

Figure 8. Battery Voltage Measurement

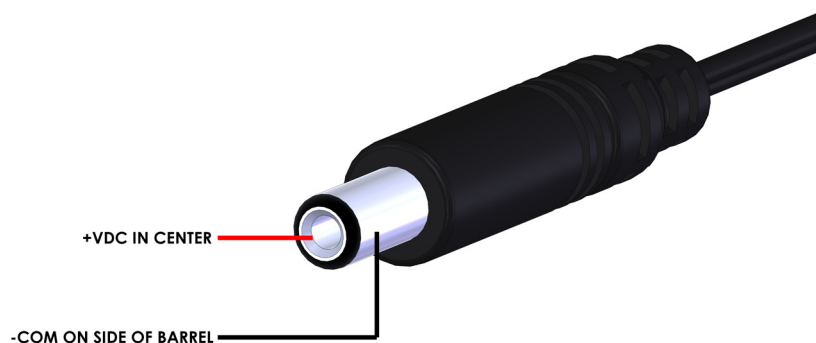

Troubleshooting Guide

Problem or Symptom	Cause	Solution
Button is difficult to press	Air is trapped in the button after assembling the cover.	Burp air after assembling battery cover. To relieve air, lift back one edge of the base, press center of rubber down, release edge.
Leaks at filter/RO Inlet or outlet connection	A rolled o-ring can block the tube from fully inserting	Use a small screw driver to reseal the O-ring and then confirm that the end of the tubing has a clean, square cut.
Low filtered water flow/ system returns to unfiltered flow automatically	Low flow rate	A system operating under low flow rates may not activate the internal flow switch. Refer to your system manual to troubleshoot a low flow condition.
No change in flow when button is pressed	Bypass knob is diverting water	Confirm that the bypass valve is in the down/closed position
	Button is not communicating with control box	Check to ensure that both the button & control box batteries are installed correctly. Replace any batteries if low power assumed.
	Solenoid valve is stuck and cannot divert water	Test the solenoid to ensure it is working, this can be done by flowing your main water, pushing the ClearLink button and closely listening for an audible click or feeling the solenoid divert by holding the control box. (This can also be done with the unit removed by flipping the control box upside down to simulate flow). If solenoid is bad refer to "Solenoid Replacement Procedure" in manual and replace Remove the solenoid and diaphragm (refer to "Solenoid Replacement Procedure" in manual) to clean out debris.
Button communication is intermittent	Button is not communicating with control box	Check to ensure that both the button & control box batteries are installed correctly. Replace any batteries if low power assumed.
	Weak signal	Different materials may block the wireless signal more than others. Try moving the button to an area on the counter that is closer to the under-sink control box.
High TDS in product water	Debris in solenoid or outlet check valve	Remove the solenoid and diaphragm (refer to "Solenoid Replacement Procedure" in manual) to clean out debris. (Best practice: Ensure all cartridges, including in-line bullet are pre-rinsed prior to installation)
Button falls into water	Users try to operate the button to see if it still works while it still has a wet board / batteries	DO NOT TRY TO OPERATE the button. Remove the two AAA batteries and place the button in a bowl and cover with rice for at least 24 hours to assist in drying it out. Do not use until completely dry.
Water leaking from Air Gap	Air gap is installed incorrectly	Create as short as possible run of the gravity drain tubing with no angles to the drain connection. Make sure your drain is located away from the disposal to reduce the likelihood of leaks or blockage.
Power light on Aquasential ClearLink PRO control box is not on	No power to Aquasential ClearLink PRO control box	Ensure AQ Smart is powered on and rechargeable battery has sufficient charge

Control Box Lights

Audible Beep	Light	Means
3 Beeps during Power up	Green (Top Window)	Power On and performing operations
1 beep per minute when water is running and 1 beep when the water is turned off.	Red (Top Window)	Option 1: Replace D Batteries in Control Box Option 2: Use A/C Adapter instead of D Batteries
1 beep per minute when water is running and 1 beep when the water is turned off.	Yellow (Second Window)	Reached Capacity in Gallons/Days; Replace Filter
1 beep per minute when water is running and 1 beep when the water is turned off.	Red (Second Window)	High TDS; Replace Membrane
1 beep per minute when water is running and 1 beep when the water is turned off.	Red (Third Window)	Leak Detected
	Blue (Bottom Window)	Wi-Fi Enabled and Paired
Power light on Aquasential ClearLink PRO control box is not on	No power to Aquasential ClearLink PRO control box	Ensure Aquasential Smart RO unit is powered on and rechargeable battery has sufficient charge.

Service

ClearLink PRO and ClearLink Connect Components Descriptions

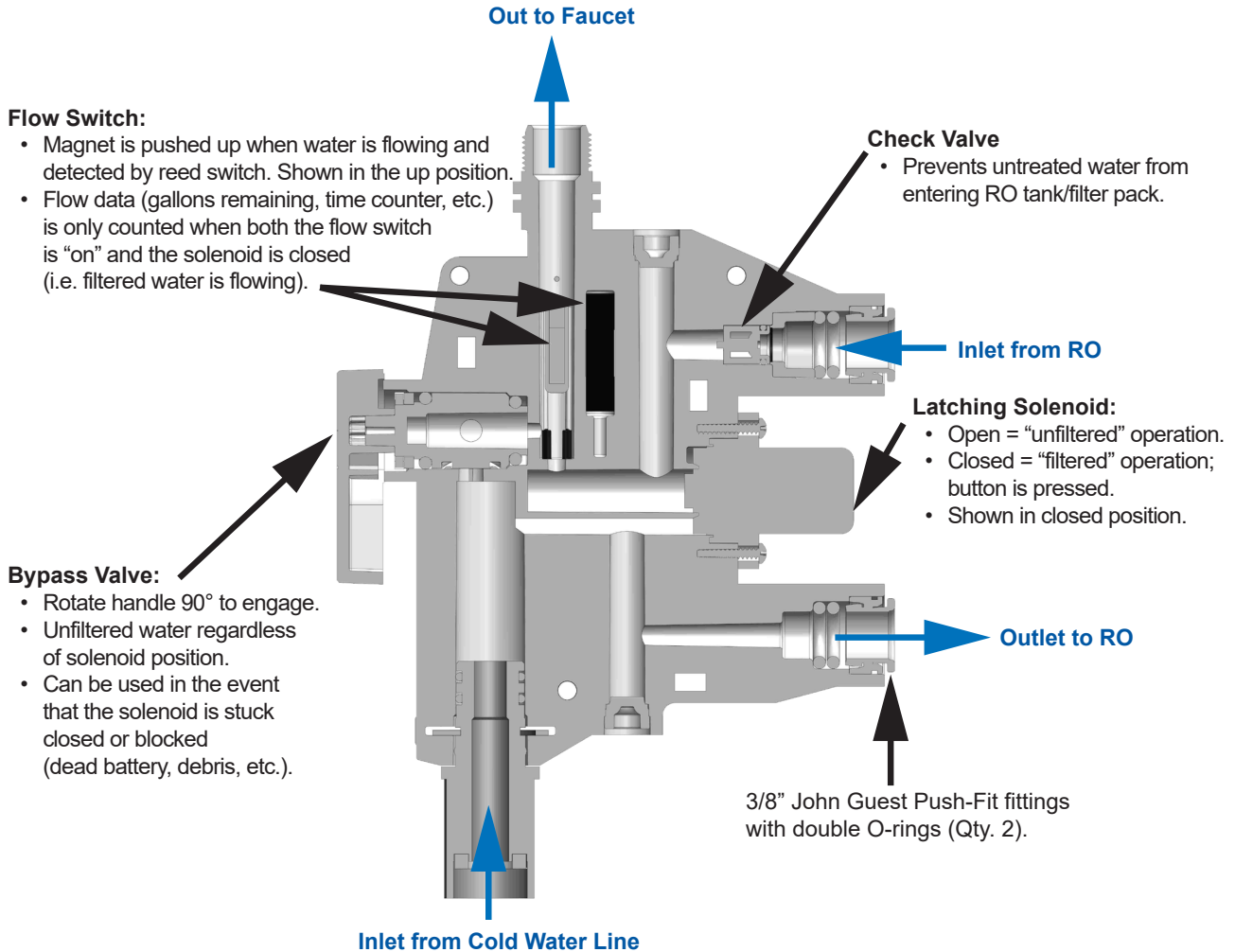

Solenoid Replacement Procedure

1. Take off the cover by removing the three rear screws.
2. Carefully remove the PCB from the manifold by releasing the three snap clips.
3. Unplug the solenoid from the PCB.
4. Take off the solenoid from the manifold by removing the 4 small screws.
5. Assemble in reverse order.

Flow Path Diagrams

ClearLink PRO, Aquasential ClearLink PRO, and ClearLink Connect

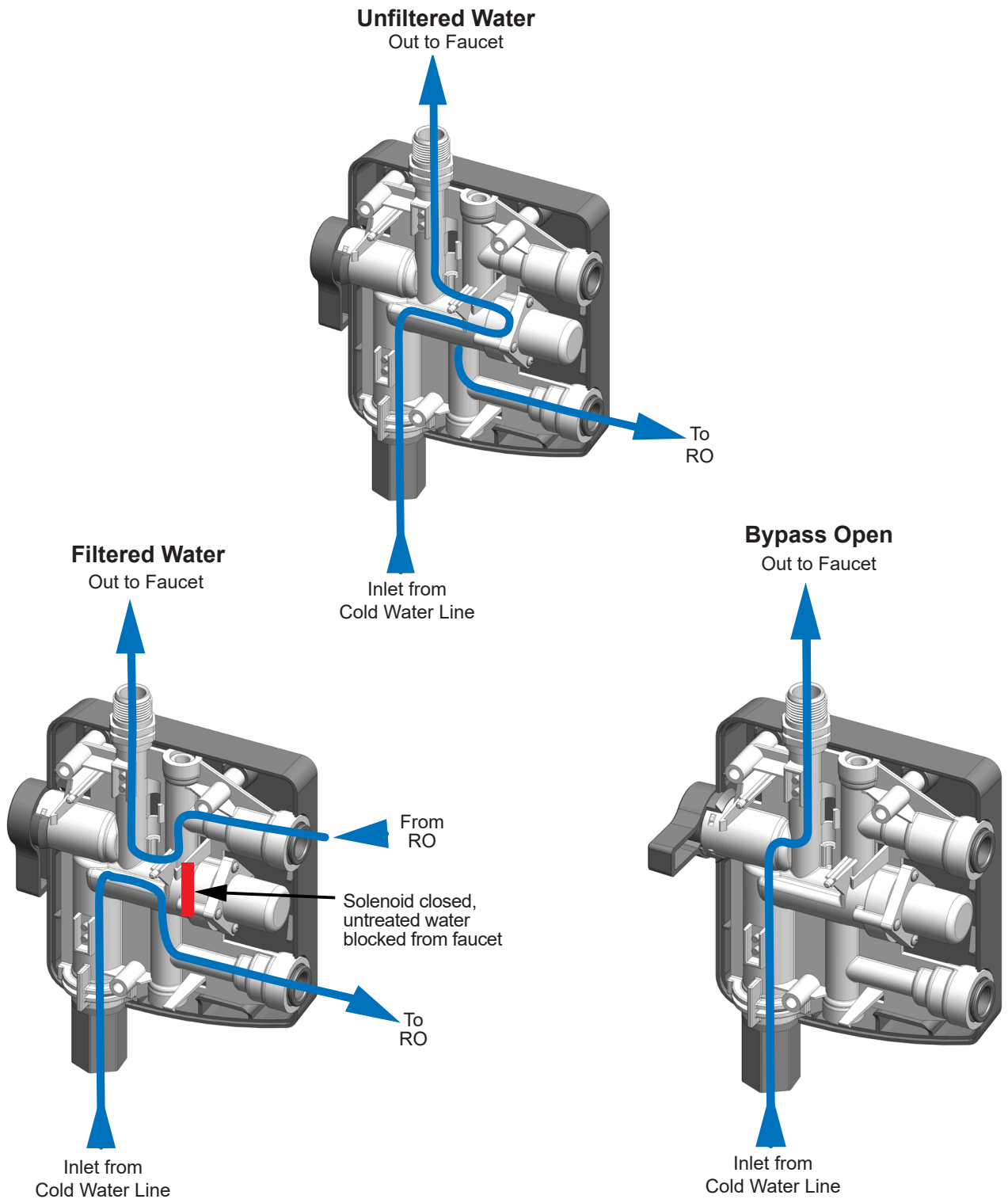

Drinking Water Connect

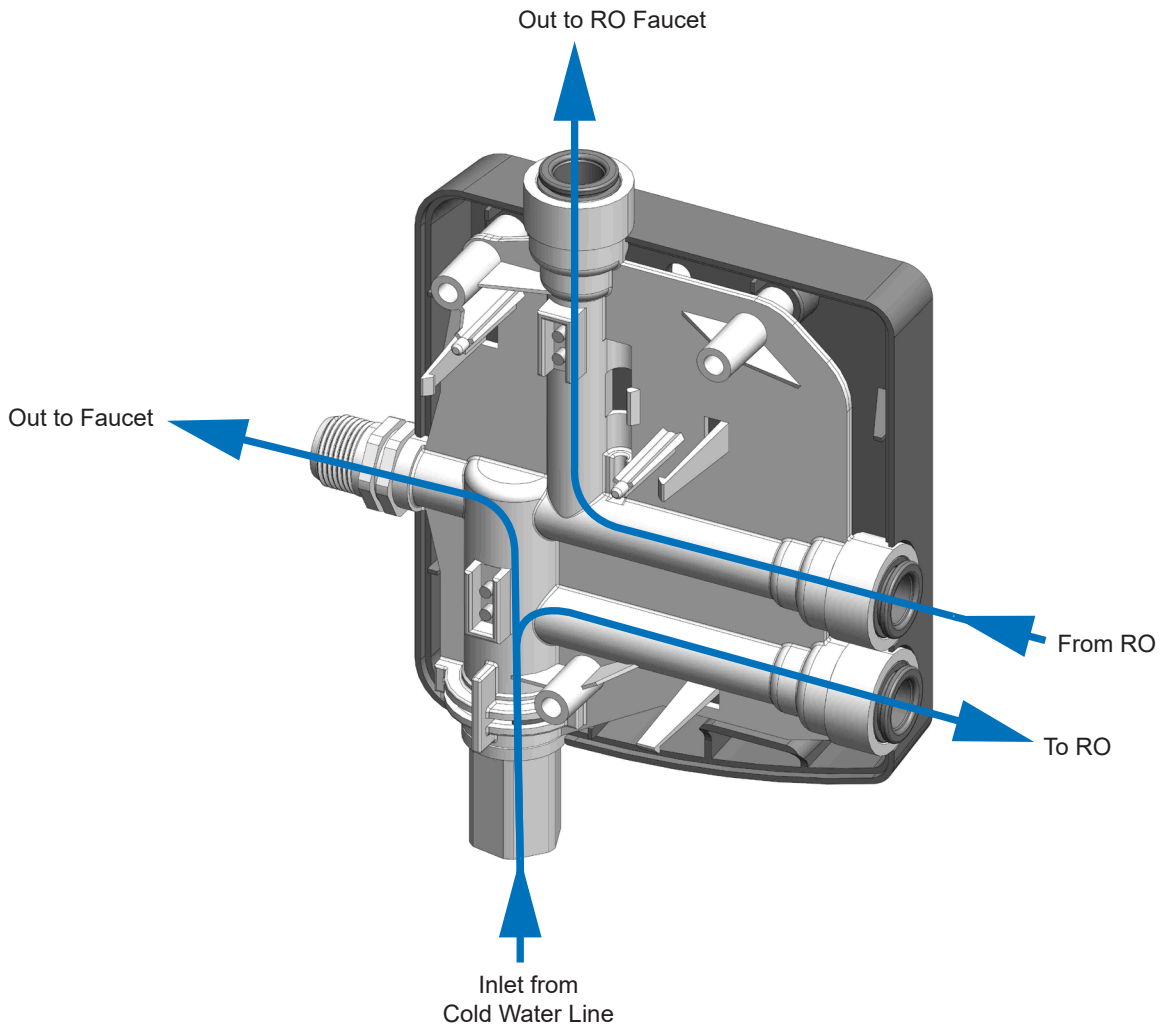

Routing Guides

ClearLink Connect: Under Sink Install with Secondary Line

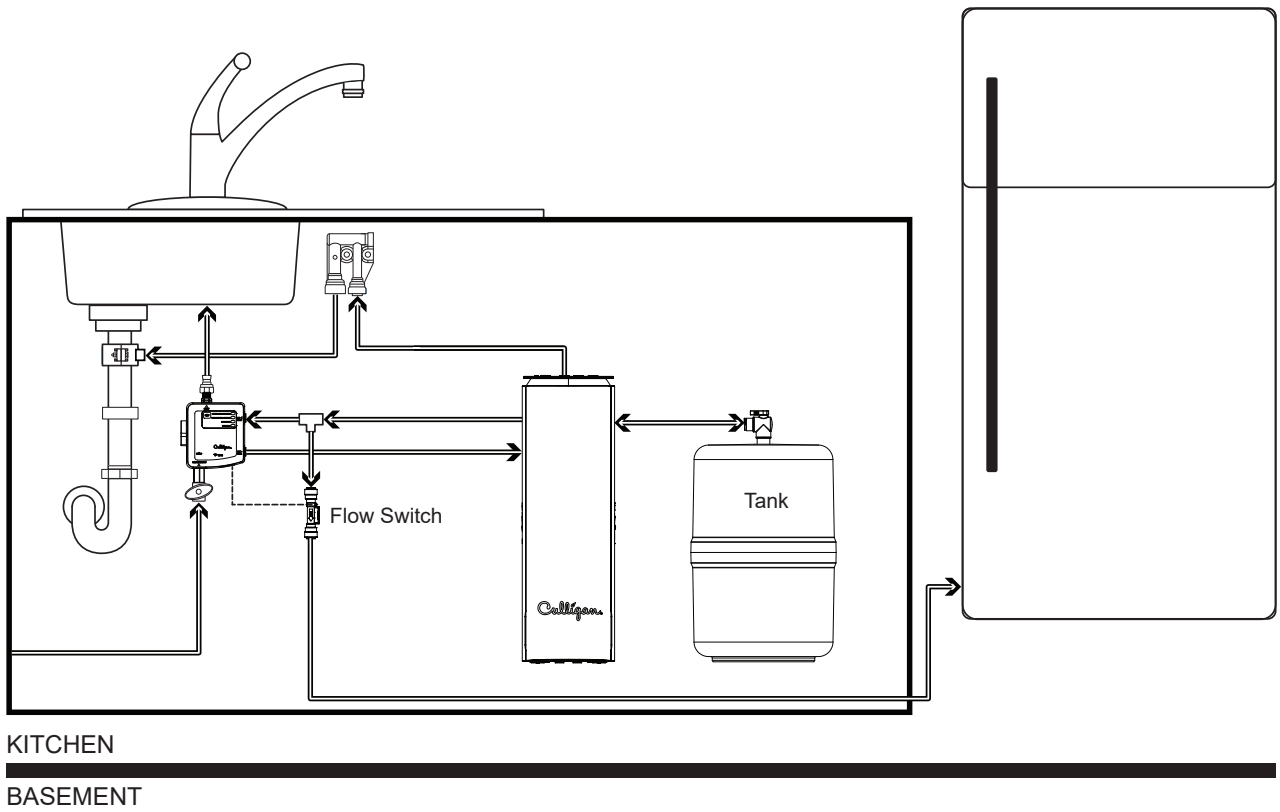

ClearLink Connect: Remote Install with Secondary Line

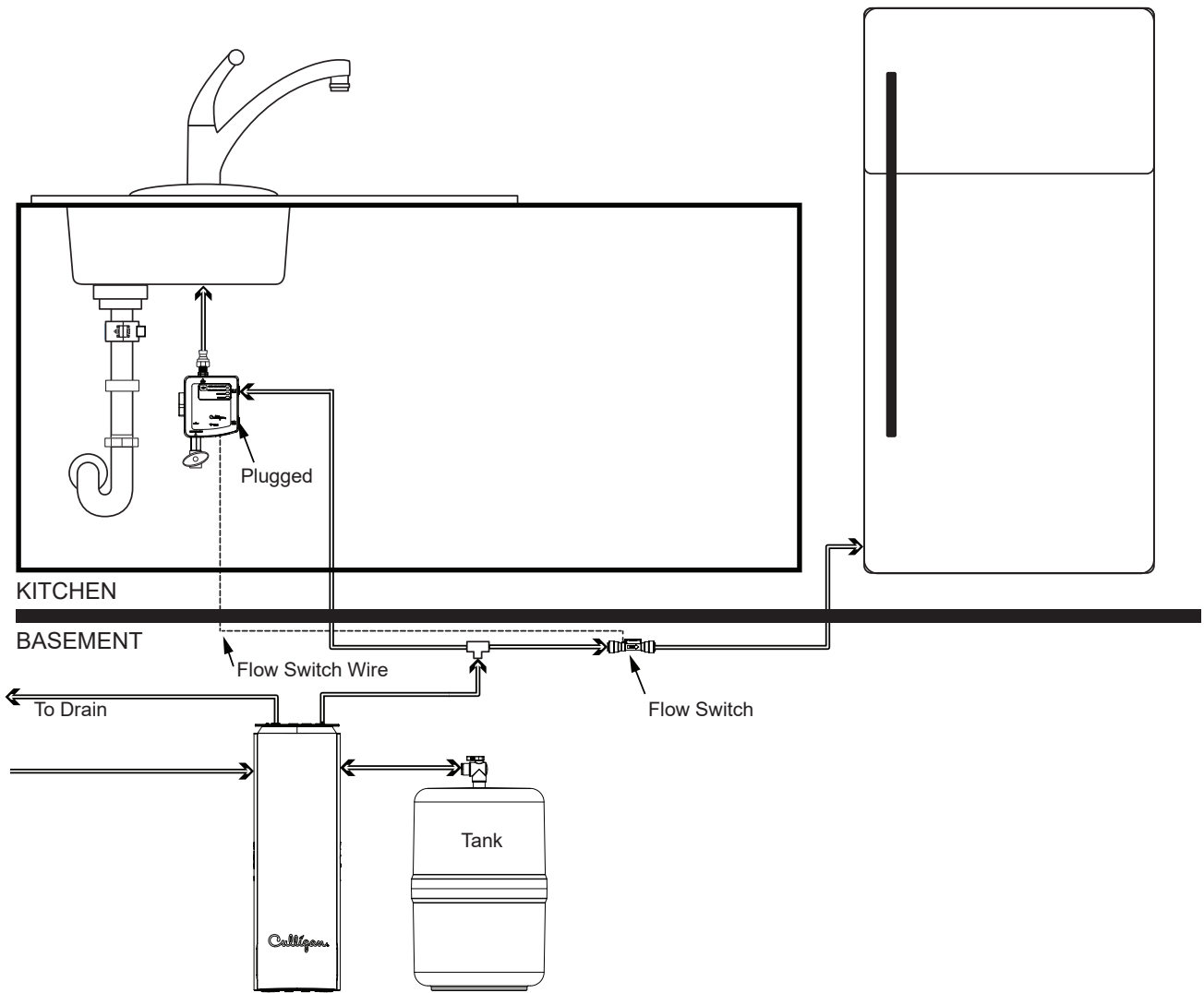

Drinking Water Connect: Under Sink Install with Secondary Line

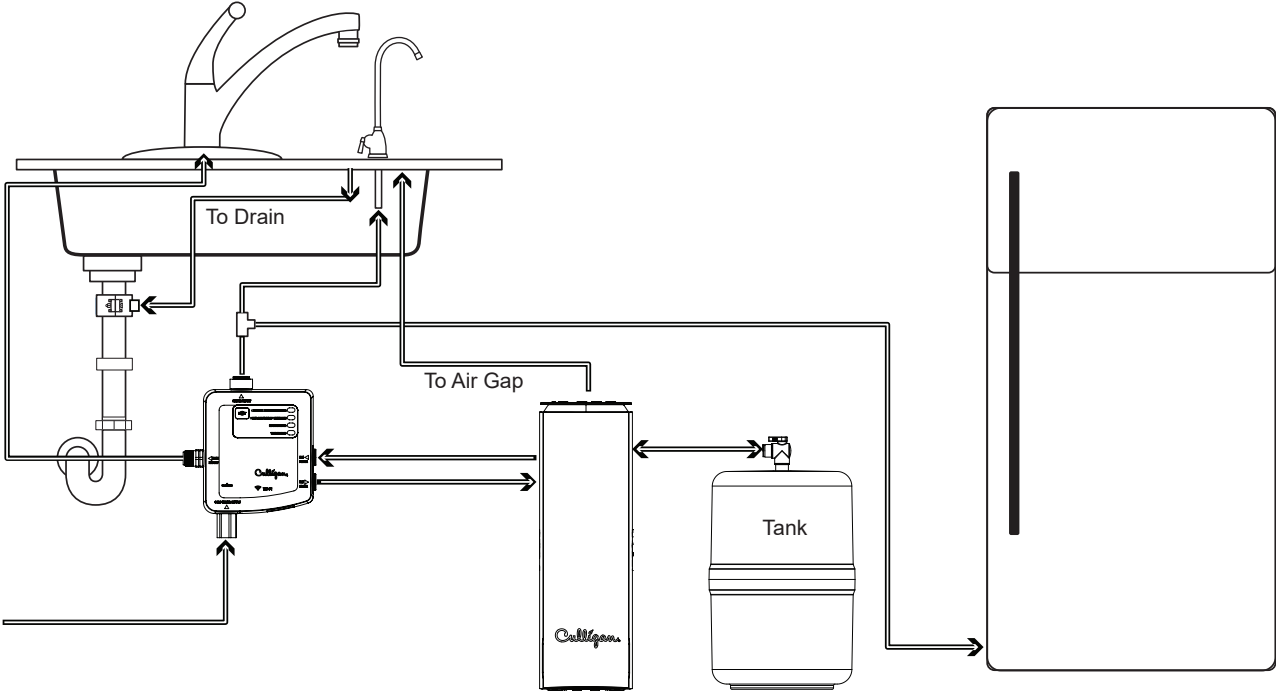

KITCHEN

BASEMENT

Drinking Water Connect: Remote Install with Secondary Line

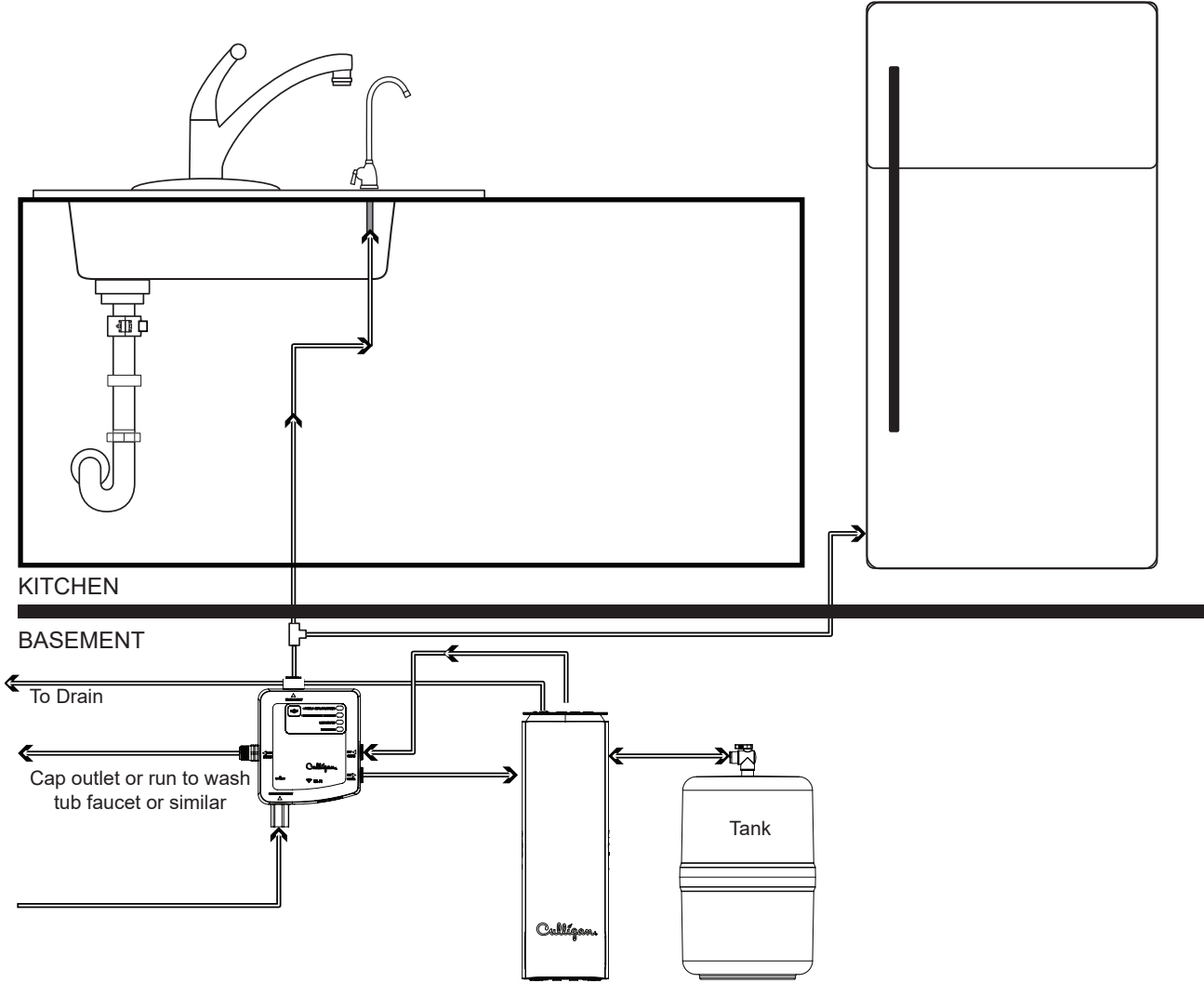

Installation Fittings and Replacement Parts List

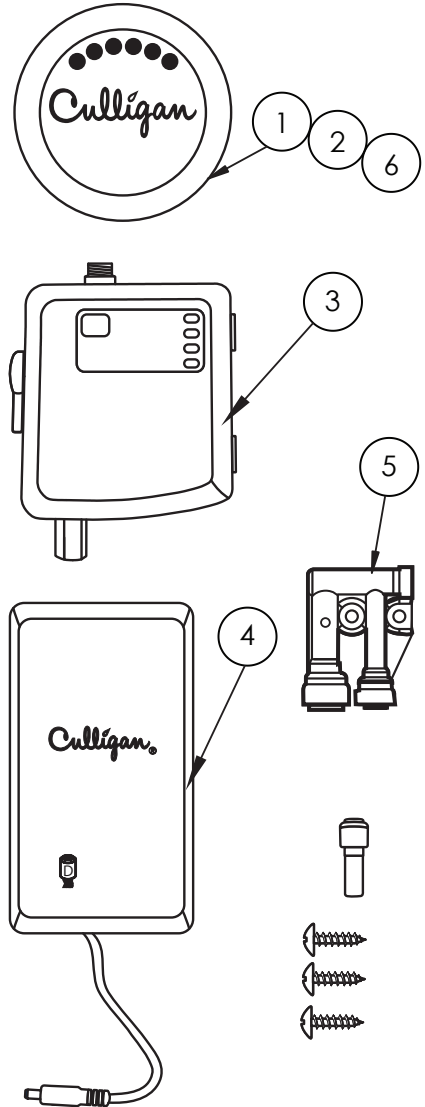

Replacement Parts			
Item	Part Number	Kit	Description
A	01029472	—	ClearLink PRO, Chrome
B	01029473	—	ClearLink PRO, Brushed Nickel
C	01029474	—	ClearLink PRO, Oil Rubbed Bronze
D	01033051	—	ClearLink Connect, Chrome
E	01033052	—	ClearLink Connect, Brushed Nickel
F	01033053	—	ClearLink Connect, Oil Rubbed Bronze
G	01033121	—	Drinking Water Connect
H	01040526	—	Aquasential ClearLink Kit, Chrome
J	01040527	—	Aquasential ClearLink Kit, Brushed Nickel
K	01040528	—	Aquasential ClearLink Kit, Oil Rubbed Bronze
1	01029450	A, B, C, D, E, F	Remote Button, ClearLink PRO, ClearLink Connect
	01041386	H, J, K	Remote Button, Aquasential ClearLink PRO
2	01029452	A, D	Remote Button, Trim Ring, Chrome Finish
	01029453	B, E	Remote Button, Trim Ring, Brushed Nickel Finish
	01029454	C, F	Remote Button, Trim Ring, Oil Rubbed Bronze
3	01029449	A, B, C	Control Box, ClearLink PRO
	01041385	H, J, K	Control Box, Aquasential ClearLink PRO
	01033035	G	Control Box, Drinking Water Connect
	01033034	D, E, F	Control Box, ClearLink Connect
4	01033128	A, B, C, D, E, F, G	Battery Box, D Batteries
5	01030130	A, B, C, D, E, F	Air Gap
6	P1031849	—	Quad-ring Replacement Pack, 10pcs per pack
*	01033141‡	D, E, F	Air Gap Mounting Bracket
*	01029455‡	—	AC Adapter (optional)
*	01033130	D, E, F	External Flow Switch with 3' Wires**
*	01033170	—	External Flow Switch, 40' Wiring Extension Kit (optional)
*	01033129	D, E, F, G	Leak Sensor**
*	01040530	—	Aquasential Clearlink Pro Ext cable, 24'
*	01035431‡	—	Solenoid Replacement Kit

*Not shown

**Not designed to work with ClearLink PRO

‡ Recommended Spare Parts



1



2



3



4



5 & 6



7



8

Installation Fittings

Item	Marketplace P/N	Description
1	MS031611	Adapter – 9/16-24 UNEF Female Thread to 3/8" OD Push-to-Connect
2	MS031612	Adapter – 9/16-24 UNEF Male Thread to 3/8" OD Tube Stem
3	MS028701	Air Gap – Twin Inlet, 1/2" MIPT, 1/4" Quick Connect
4	MS028702	Air Gap – Twin Inlet, 1/2" MIPT, 5/8" Barb Insert
5	MS028703	Decorative Cap
6	MS028704	Air Gap – Twin Inlet, No Fitting, No Cover
7	MS028705	Drain Adapter Fitting – 3/8" Push-Connect
8	MS028706	Drain Adapter Fitting – Universal, 3/8" Push-Connect

Two-Year Limited Warranty

This warranty applies to the button, control box and battery box. This warranty covers defects in material and workmanship only for 2 full years from the original date of delivery. Culligan will replace any part which in Culligan's opinion is defective, unless: (1) any part of the unit has been subjected to any type of tampering, alteration, or improper use after delivery, or (2) it has been repaired by anyone not approved by Culligan.

This product has been designed solely for use as a water filtration control. It is NOT warranted against freezing or surges in water pressure, and neither this product nor its parts is warranted against defects or deterioration caused by uses for which this product was not expressly intended.

THE FOREGOING WARRANTY IS EXCLUSIVE AND IN LIEU OF ALL OTHER WARRANTIES, EXPRESSED OR IMPLIED, WHETHER ORAL OR ARISING BY USAGE OF TRADE OR COURSE OF DEALING, INCLUDING, WITHOUT LIMITATION, ANY WARRANTIES OF FITNESS OR MERCHANTABILITY. THIS WARRANTY IS THE PURCHASER'S SOLE AND EXCLUSIVE REMEDY, IN NO EVENT SHALL CULLIGAN BE LIABLE FOR ANY ANTICIPATED OR LOST PROFITS, INCIDENTAL DAMAGES, CONSEQUENTIAL DAMAGES, COSTS, TIME CHARGES OR OTHER LOSSES, WHETHER BASED ON BREACH OF CONTRACT, TORTIOUS CONDUCT OR ANY OTHER THEORY, INCURRED IN CONNECTION WITH THE PURCHASE, INSTALLATION, REPAIR OR OPERATION OF THIS PRODUCT. CULLIGAN DOES NOT AUTHORIZE ANYONE TO ASSUME FOR IT ANY LIABILITY OR TO MAKE ON ITS BEHALF ANY ADDITIONAL WARRANTIES IN CONNECTION WITH THE FILTER HOUSING OR ANY PART THEREOF.

Index

A

About Models [7](#)
Alert Icon [22](#)
Alert Indicator [22](#)
Android [24](#)

B

Battery Icon [22](#)
Button [22](#)
Button Display [22](#)

C

Capacity [11](#)
ClearLink [23](#)
ClearLink Connect [7, 23, 34, 35](#)
ClearLink Pro [7](#)
Components [31](#)
Control Box [23](#)
Control Box Lights [30](#)
Control Box Operation [23](#)
Cport Viewing [28](#)
Culligan Logo [22](#)

D

Drinking Water Connect [8, 23, 33, 36, 37](#)

E

External Flow Switch [16](#)

F

Filter Capacity Lights [22](#)
Flow Path [32](#)
Flow Switch [16, 17, 18](#)

I

Install [34, 35, 36, 37](#)
Installation [10, 12](#)
Installation Fittings [38](#)
Installations Best Practices [29](#)
Introduction [5](#)
iPhone [26](#)

L

Leak Sensor [18](#)

M

Materials [10](#)
Models [7](#)

O

Outlet [16](#)

P

Pairing [24](#)
Pairing to Smartphone [24](#)
Pair to Android [24](#)
Pair to iPhone [26](#)
Parts [10](#)
Parts List [38](#)
Power [23](#)
Precautions [10](#)

R

Remote Install [35, 37](#)
Replace Batteries [23](#)
Replace Filters [23](#)
Replacement Parts List [38](#)
Replace RO Membrane [23](#)
Reset Button [23](#)
Routing Guides [34](#)

S

Safe Practices [6](#)
Serial Number [6](#)
Service [31](#)
Setting Capacity [11](#)
Solenoid [31](#)
Specifications [10](#)
Switch [17](#)
Switch Wiring [17](#)
System Startup [19](#)

T

TDS [11](#)
TDS Function [11](#)
TDS Icon [22](#)
Tools [10](#)
Troubleshooting [24, 29](#)

U

Under Sink Install [34, 36](#)

W

Warranty [40](#)
Wi-Fi Icon [22](#)
Wire Extension Kit [18](#)
Wiring [17](#)